

DEMI Low Drive Power Amplifier

(Preliminary version)

DEMI Part Number _____ LDPA SN _____

Power Out Maximum:	75 W linear	Other _____	
RF Output Option:	Common	Separate TX and RX (Split)	
RF Drive Requirement	Maximum 10 mw	Other _____	
DC Power Requirement:	11.5 - 15.5 VDC @	20 Amp Max supply for head room.	
Noise Figure and Gain:	< 1.0 dB maximum @ 17 dB gain minimum		
LNA Option	YES	NO	Fused Coax Bias
DC Power Enable	Remote	Switch Panel	
LNA Enable	Remote	Switch Panel	
Transmit Enable	Remote	PTT-L (RCA Connector)	
Sequencer	Enabled		Disabled
Sequencer Outputs	Color	Transmit	Receive
1 (Sequencer step 1)	Brown	Open	High (750ma)
2 (Sequencer step 2)	Red	High (750ma)	Open
3 (Sequencer step 3)	Blue	Low (100ma)	Open
Ground	Green	Ground	Ground
Ground	White	Ground	Ground
Ground	Black	Ground	Ground
Other Options:			

Configuration Overview: The DEMI LDPA or Low Drive Power Amplifier is designed specifically to interface with the Flex 6700 but may interface with any transceiver or transverter that provides between 1 and 10mW of output power. When your LDPA was assembled, it was configured by DEMI, per your specifications, to interface easily and directly with your desired transceiver. As indicated above, some user options and configuration needs to be selected before delivery and may or may not be user changeable. Let's review your configuration and verify that your interface will be easy and trouble free. Please refer to the chart above.



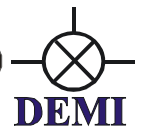

DEMI Part Number Verification: All DEMI LDPA's contain the operating band within the part number, i.e., 2MLD is equated to the 2 meter band of 144-148 MHz operation. The part number will also identify the amplifiers MAXIMUM linear output power. The actual output power will be circled or indicated in the other section if a custom level was required. These levels are the **linear** output power levels that should not be exceeded if linear operation is expected. In most cases, the amplifier is capable of higher output power but is not recommended because of excessive "on the air" distortion products.

RF Output Option: The RF output option is either a single port (Common RF) for both TX and RX or there will be two separate ports, (Split RF) one RX and one TX. For the common port, a PC board RF relay is utilized that allows the output configuration to be changed at anytime if the user changes their system requirements at a later date. This will be covered in detail later in this document. The common port relay (the TR relay) is controlled by the Push-to-talk (PTT) circuit

RF Drive Requirement: The RF drive level requirement is specified with the standard level being a maximum of 10 mw. The input drive connector (labeled TRANS) is shared with the RX out to the transceiver. It is a common (both TX and RX) in/out port set up for transceiver operation as a standard configuration. This allows the use of an internal relay to bypass the TX input and RX output to an additional BNC port (labeled BYPASS) on the enclosure to route your transceiver I to a different amplifier or transverter when the LDPA is disabled.

DC Power Requirement: The DC power requirement is listed and should be used as a guideline. Please include some "Buffer" in your power supply to eliminate voltage drop delivered to the Amplifier. If a custom lower power is requested, a lower current power supply may be utilized.

Noise Figure and Gain: The LDPA contains a receive preamplifier. Its noise figure and gain listed are the minimum requirements and most amplifiers exceed these specifications. In utilizing the latest PHEMPT technology, we have designed the pre-amplifier with diplexing, band pass filtering and gain management in mind.

LNA Option: If the use of an external receive pre-amplifier is desired, the LNA option is provided which when enabled, by-passes the standard LNA and switches its sequenced control to the external Preamplifier unit of your choice. The DC requirement of the external device is either supplied to the coax via a Fuse or directly through the AUX connector sequencer output as indicated. The option is either controlled by a front panel switch or remotely through the C232HM interface.

DC Power Enable: This either accomplished by a front panel switch with the standard configuration or controlled remotely through the C232HM interface from the Flex Transceiver.

Transmit Enable: The TX Enable for the standard configuration is controlled with a PTT-L (requiring a connection to ground) through the male RCA connector. If the Remote Option is specified, through the C232HM interface cable. In both cases, the sequencer is enabled unless specified. If disabled, the PTT connection will go directly to the amplifier to key it without any delay.

Sequencer Outputs: All Sequencer outputs are contained in the 6 conductor cable extending from the AUX connector and are indicated by color on the chart.

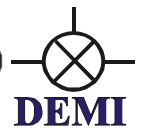
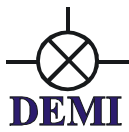

Other Amplifier Options:

The amplifiers may be configured with different options depending on your specific operation. The “TX out - RX in” side or “Antenna Port” of the amplifier may share a common connector through an internal TR relay or be configured as two separate ports if driving a larger power amplifier. As briefly discussed before, the amplifiers RF power detect voltage may be routed out the AUX jack if you intend to remote mount the amplifier. The sequencer outputs may be configured to switch 12VDC or to ground on either TX or RX. An external DC voltage such as 28 VDC may also be switched if provided. Keying of the amplifier has options. Either a high or low will activate the amplifier directly or via the sequencer. Keying may also be done with a voltage signal on the input coax if desired to eliminate a configuration wire and if the transceiver being utilized has that capability. There are also empty pins within the AUX connector.

FLEX-6700/6500 Performance Enhancement Circuits:



One feature that is designed for the FLEX transceivers is the XVTR bypass function. When the LDPA is powered off, the signal from the FLEX XVTR port enters the “TRANS” port and bypasses around the amplifier to the “BYPASS” connector on the rear panel. This enables the ability to route the XVTR signal to another amplifier or transverter making it possible to “Daisy Chain” a 2MLDPA, and a 4MLDPA, then continue on to a higher frequency transverter and/or a switch box. Standard PTT keying of the LDPA’s may be controlled by one of the three relay controls from the FLEX transceiver.

The LDPA’s have a standard gain LNA to establish an excellent system noise

figure. If the gain is either excessive or not enough, the RX gain controls within the FLEX transceivers are used for adjustment. It may even be desirable to use the RX attenuator function of the FLEX.

In the same fashion, the output power of the amplifier, since it is linear, is controlled by the drive level from the FLEX transceivers. The drive should be adjusted in the CW mode to obtain 9 bars on the bar graph of the LDPA which is the full specified power. This should be near the maximum power derived from the FLEX XVTR port. Then, at any time the drive level may be lowered to operate at a lower output level. Driving the LDPA’s with anything more than the specified XVTR level will drive the amplifier out of its linear

High Dynamic Range Receive Preamplifier / Filter Section:

With the latest PHEMT technology, we were able to design one of the most robust low noise preamplifiers available to the Amateur Radio market today. This ensures that lowest amount of possible IMD interference will be introduced to the transceiver while maintaining a low system noise figure. Utilizing a diplexer between the LNA and band pass filter, high levels of reflected out of band signals and noise are absorbed and not allowed to “re-mix” in the LNA which produce the intermodulation distortion. Gain is a nominal level of 17 dB to maintain system noise figures and final gain is managed by the FLEX transceivers with its gain and attenuation controls.

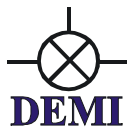

What is NEW: New is the availability of an external LNA operation option. We have added this option so that the LDPA's can control a Mast Mount RX preamplifier and bypass the internal LNA. This allows the user to increase the signal to noise performance without increasing the overall system gain. Using the manual switch on the front panel or with the remote option, the LDPA's LNA is bypassed, then supplies a sequenced DC powered signal for your mast mount LNA either through the coax or on an independent line through the AUX connector.



Built in sequencer option:

As in the past, we have provided a simple 4 step sequencer in all amplifier versions. It is all solid state switching. This is a perfect complement to the FLEX transceivers allowing it to be completely isolated and dependent to the specific amplifier in use. The sequencer is intended to provide additional switching circuits for controlling high performance 4M and 2M system utilizing high power amplifiers and mast mount preamplifiers. With simplicity in set up, and some simple common sense when using, this sequencer is an economic alternative to any external device on the market that would be consider if required. All external switching signals are accessible through a multi-conductor cable from the AUX connector located on the amplifiers back panel. The sequencer activates the LDPA but it may be bypassed and the LDPA may be keyed directly with an external "Push to Talk" circuit either High or Low.

Relative output power monitor circuit:

The relative output power monitor bar graph display is standard in all amplifiers. This monitor circuit and 10 segment LED display is calibrated for maximum linear output at 9 bars. The output monitor may be calibrated to indicate other levels if required. Understand that is a relative forward power meter and is not a reflected power meter. The RF detection circuit may be used separately or in conjunction with the 10 segment LED display in case of a requirement to monitor output power with the amplifier in a remote location. Consult DEMI for this option.

Variable Speed Fan:

The LDPA will have a cooling fan attached to the heat sink. The fan is controlled by a variable speed circuit on the amplifiers circuit board. The activation and speed will vary depending on the heat sink temperature and the ambient air temperature. The fan is required for the 2MLDPA but may be an option for the 4MLDPA if digital or FM use is not required.

Remote Mode Option:

New to this design is an added option for the ability to control all functions of the LDPA with the click of a Mouse. Smart SDR Software v1.10 or newer is required to be installed in your Flex transceiver. First, you will be able to toggle the LDPA on and off for use. Toggling the LDPA off places it in the Bypass mode to allow additional amplifiers or Transverters to utilize the same port utilized by the LDPA. You will also have full control of the external Mast Mount LNA control that was described previously. It will allow the user to bypass the LDPA's internal RX amplifier and



introduce a sequenced controlled voltage to an external device of your choice either through the RF coax or the LDPA's AUX connector. This allows the ability to remotely locate the LDPA for whatever reason! If you have ordered the "Remote Option", you will have a C232RM interface cable that plugs in to one of the two USB ports or hub utilized with your FLEX 6500/6700 Transceiver. This cable will also include the PTT function for the LDPA freeing up one of the three relay controls to be

utilized by other accessories. Then, if other features become available such as output power monitoring, they will be introduced to further enhance the compatibility of the FLEX and LDPA.

Interfacing: The interfacing starts with a complete understanding of your transceiver and manual relating to the low level transceiver connections. The manual should cover the "enabling" of the port and its PTT functions. Hopefully, you have decided on how this amplifier is to be interfaced before the time of order so we were able to configure it correctly to fit your requirements. If you find that this amplifier is not configured correctly, refer to the **Option Setup** section later in this manual concerning changing of configuration or contact us directly. Some configurations are user changeable and detailed instructions are included.

Start the interfacing by prepping the DC power cable. Select you connections to your power supply and install them on the cable. Remember to utilize a power supply with enough head room to operate the amplifier. A 20 Amp supply would be adequate.

Next utilize good quality 50 ohm cable for your transceiver to "TRANS" connection. This connection is a very low level TX signal that also carries the amplifier RX signal back to the transceiver. It can be of any length up to hundreds of feet if good quality cable is utilized. Remember, whatever length you chose to use, if the loss is less than 6 dB, the LDPA will operate

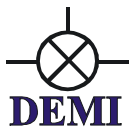

correctly. We find with short lengths (under 10 feet) that simple RG-58 type BNC cables work fine with or without adapters to your transceiver if required.

For the high power antenna connection, use a good quality RG-8 type coax at the minimum. Avoid using adapters to the Type "N" connector on the LDPA and depending on the length, adjust the quality of coax to keep the loss at a minimum. If you chose separate RX and TX antenna ports, cable it accordingly for your system.

With the standard or "Non Remote" operation, the PTT connection is the RCA connector extending from the supplied 9 pin AUX connector. Utilize the recommended connection of your transceiver that will enable transmit of the LDPA with a connection to ground. The 6 wire cable extending from the AUX connector are the 3 outputs of the Sequencer and 3 ground connections. See the front page for the Color codes. You may wire the sequenced wires or do it later after initial testing but, connect the supplied cable to the AUX connector for PTT control. The bypass connector may be connected if desired or connected it after initial testing.

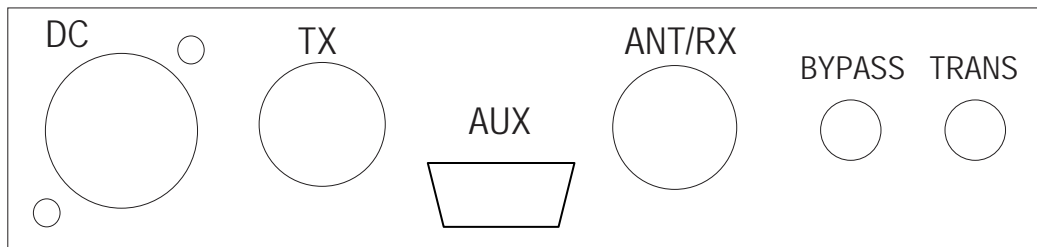

Rear Panel view

Operation: After the above interfacing the LDPA to the transceiver it is ready to go. There are no adjustments required to make to the amplifier on either transmit or receive. The below steps are recommendations only to very correct operation.

An Important note: It is recommended that during the initial setup of the LDPA, that it is not connected to your complete system with a HPA or mast mount LNA. All aspects of the amplifier performance should be tested before a complete installation is made. Drive levels of your transceiver need to be established and proper switching needs to be verified before complete integration. It recommended that the LDPA be directly connected to an antenna or a 50 ohm dummy load for the initial testing.

Standard or "Non-Remote" Operation

- 1. Power your transceiver and LDPA "ON". The Fan on the LDPA may have started as soon as the power supply was connected. It is not connected to the switch and is temperature controlled. If it is running, the heat sink is above 75 degrees. If your transceiver cycles during power up, it may key the LDPA. This is indicated by the Red "XMIT" light and the sound of relays cycling. Verify that the transceiver is in "receive mode" and that the red XMIT light is off on the LDPA. If not, shut off your HF transceiver and check the PTT

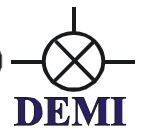

connection with the "TRANS" cable disconnected from the amplifier. If both transceiver and amplifier are in their receive modes, tune the transceiver to a common operating frequency.

2. To check receiver performance, observe the noise level in the transceiver on the "S" meter and by ear. Cycle the LDPA power on and off to detect the noise increase. With the Noise figure of the built in LNA, you should be able to detect the thermal noise of 50 Ohm dummy load or hear the band noise if you have an antenna connected. If the noise floor is too high, adjust the gain control of your transceiver till slight movement in the "S" meter is detected or where it is desired. Power the Amplifier on and off to verify the change. The RX gain in the transceiver may be adjusted at anytime afterwards to increase or decrease the noise floor or S-meter reading. It is all user preference. If you plan to use an external or mast mount LNA, this level will need to be re-adjusted. Find a signal on the band or use a signal generator to determine minimum signal or maximum signal compression level if desired.
3. Test the amplifiers' transmit section next. Use the CW, FM or TUNE mode because a steady carrier is required to set the output level. Preset the transceivers output power to minimum without placing the transceiver into transmit. If it is not possible, disconnect the "TRANS" connection before placing the transceiver into transmit. Place the transceiver into transmit and check the "XMIT" light. If the PTT circuit is connected correctly, the red "XMIT" light on the transverter will switch on. While observing the built in relative power meter or an inline RF power meter, slowly increase the transceivers power control in whatever mode you choose to achieve the maximum output power level not exceeding the linear power rating specified on the front sheet or 9 bars on the relative power meter. Then do not exceed the maximum power level or just light the 10th bar. If you cannot achieve the specified power rating, than the LDPA is either configured wrong or the drive level of your transceiver is lower than expected. If so, continue to the **Option Setup** section and possibly re-configure the amplifier before further testing.
4. You may re-adjust both RX and TX levels of your transceiver again if desired. The TX level is utilized to set the desired output of your LDPA of any value less than its maximum. Verify the maximum current being drawn by the LDPA is 18 amps or less.
5. The AUX connector mate may be now wired for your installation. If you require something other than what is indicated on the front page, please see the **Option Setup** section for further details. Also read further about interface and testing a mast mounted LNA in that section.

Remote Operation: Have version v1.10 or later installed before attempting setup. Anything older will not allow the USB interface to function. With the correct version installed it will show the operating functions of the LDPA. It is then a matter of switching to the correct band and attempt to control the LDPA. If the Remote Option is ordered, all other options are installed and ready to be "toggled" if all cabling has been completed.

Start by applying the DC power to the LDPA. You may now notice that there are no switches on the front panel of the LDPA. With your Flex 6000 series transceiver correctly set up, start by switching on the LDPA. The "On" light should be lit. If not, check all cabling, DC power supply connections, and transceiver configuration.

If lit, then proceed by reducing the output power of the transceiver to minimum. Then operating in FM, CW or TUNE, enable the TX by placing the transceiver into Transmit. The "XMIT" light of the LDPA should be lit. Now slowly increase the TX power watching the LED bar graph display of the LDPA. Increase the power until all but the last LED is lit. This is the maximum linear power output. Verify the amount of DC current being drawn by the LDPA 15 amps or less.

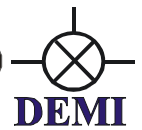

Next is to verify that the LNA option is switching. Toggle the LNA with the transceivers control. You should hear or see/hear the noise level change verifying that the internal LNA is being switched in and out. You can then connect your external LNA and cycle it. When the internal LNA is bypassed, the External LNA is enabled. If your external LNA requires bias through the coax, install the provided 1 amp fuse. **CAUTION!** This will place DC voltage on the RX/ANT connector during receive. If there is any other loading besides the external LNA such as a dummy load or a directly shorted coax or antenna, it will blow the Fuse. After all, that's what it is for!

Installation Complete: Basically, the LDPA is ready to use and may be integrated into your system. Connect as you wish to use it in your system. If your system requires the use of the sequencer or you desire to implement it please refer to the **Option Setup** section of this manual.

General Operation: General operation of the LDPA, if everything is adjusted correctly, the LDPA should be transparent to the transceiver and the user. Some cautions should be taken when operating CW or VOX. Operating the transceiver in a "Full Break-in" mode is not recommended. Because of the mechanical relays in the amplifier, if the COM output option is configured, there will be too much delay to operate "Full Break-in" effectively. AND—the relays would be abused if "Full break-in" is enabled. It is best to operate in "semi break-in" and adjust the delay of the PTT on your transceiver to match your comfortable CW operating speed in a way that the delay will hold the PTT until your transmission is complete. All LDPA's will be delivered with the sequencer enabled, this delay will need to be longer to allow all components within the system (Power amplifier, LNA, relays,) to complete their transition if utilized. If the stock LDPA is to be used alone, the transceiver PTT signal may be connected directly to the Amplifier's PTT input if the sequencer is bypassed. This will shorten up the delay but will not allow "full break-in" without relay chatter. See the **Sequencer Operation** in the **Option Setup** section of this document.

Do not disable the Fan. The LDPA needs to dissipate over 150 watts of heat at maximum output power. The thought may be that it is acceptable for SSB and CW operation but no. We have found the ambient fan noise of the amplifier to be un-noticeable in casual use and is only "wound – up" full in the most extreme operating conditions where the heat in the shack never drops below 85 F and the amplifier is operating at extreme conditions where it need the maximum cooling.

Option Setups:

Common or Split RF connections: To change from a Common port to separate ports, install a type "N" or UHF connector in the TX slot of the rear panel with coax. C4 is then removed and the coax is directly soldered from the TX connector to L16. The shield is soldered to the bare ground near the relay. The relay is left installed and used on the RX side like a normal common port operation. To go from a Split port to a common port, remove the TX connector coax from the board and install C4. It needs to be a capacitor that is 100 pF or larger in value and able to handle 100 watts of RF at the operating frequency. You may short the connection directly with a heavy short wire but the use of a capacitor is advisable for isolation,

Sequencer: The sequencer configuration may be changed at anytime. If it was specified to be utilized, the LDPA is connected to the 4th and last step of the sequencer. It is wired to the #4 point on the circuit board in the sequencer section. This is a "LOW" on transmit. The other connections are indicated on the front page and wired to the AUX connector with color code.

Step 1 +12VDC on RX for a preamp @ 750 mA maximum

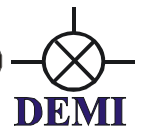
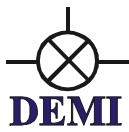

Step 2 +12VDC on TX for a TR relay (around the preamp) @ 750 mA maximum

Step 3 Ground on TX to key a HP power amplifier. Sinks 100 mA maximum

Optional Sequencer Connections:

Step 1 and 2. They can be connected to switch higher DC voltages. The DC voltage is applied to the DC1 and DC2 connections on the board (30VDC maximum).

Step 2 TL2 is a secondary connection to the second step. It is a "LOW" on transmit. It can be used to drive a relay or key an amplifier but an external isolation device should be utilized. It will sink 50 mA maximum

Step 3 and Step 4. They have secondary outputs that are both "High" on transmit. They are labeled PHA3 and PH4. These should be isolated from devices that require high currents and are intended to drive low current devices or Pass transistors or FETs. They will source 50mA.

Sequencer Bypassing: The Amplifier's sequencer may be by-passed to eliminate switching time delays but is only recommended if the Amplifier is to be used without any other system components such as LNAs or power amplifiers. In this case the external PTT input of the Amplifier, Pin 5 of the AUX connector may be connected directly to the Amplifier's PTT input (see component placement document) near C39/CR9 (PTT-L) bypassing the sequencer Remove the wire coming from "4" of the sequencer.

Relative Power Meter: The bar graph display is a relative power meter and is driven by the directional coupler and RF detector circuit found in the Low pass filter section of the board (CR1, C50) RF is detected and converted to DC voltage and conducted to the Bar graph display on the front panel. If you find that you operate the LDPA at any other level than what we have calibrated it to (9 bars) you may change it by adjusting VR1 on the display board. If remote metering is desired, the voltage may be routed to an empty pin on the AUX connector by connecting a wire to any DET connection on the board. They are near C50/CR1 or C37/R38 (the level adjustment pot)

LNA Bias Option: Unless specified, the sequenced output for a LNA is supplied through the AUX connector. If you later desire the bias to be supplied through the coax you may do so. Install a leaded choke capable of handling the required current of your Mast Mount LNA at the L30 position. It is at the corner of the K2 relay. Then remove the wire from Pin 1 of the AUX connector or run a new wire directly from the "1" via in the sequencer to the L30 choke. Then remove L17 (if installed) and place it in the L18 position. Now for safety, this line should be fused inside of the LDPA.

If the LNA bypass relay is not installed and you later desire it, it requires the PC board to be removed for its installation. If required, please consult DEMI for this options installation.

System Testing: For mast mount LNA operation with the basic Amplifier or with an external high power amplifier, all tests should be done without RF applied. Verify that the switching is completed in your desired sequence and gradually add in external components as verified. The last should be the Amplifier's RF applied. At the lowest level. All testing can be done without coaxial cables connected until RF is applied. Connect the Amplifiers "TRANS" cable last.

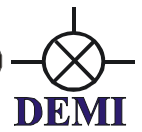

Standard Auxiliary Connector Pin Out					
Pin #	Function	TX	RX	Color	Comments
1	Seq. Step 1	Open	High (750mA)	Brown	Bias on Coax/Fused
2	Seq. Step 2	High (750mA)	Open	Red	
3	Seq. Step 3	Low (100mA)	Open	Blue	
4	Open				
5	PTT-L	Low	Open	RCA Conn.	GND to TX
6	GND				For PTT
7	GND				For Sequencer
8	GND				For Sequencer
9	GND				For Sequencer

Remote Option Auxiliary Connector Pin Out					
Pin #	Function	TX	RX	Color	Comments
1	Seq. Step 1	Open	High (750mA)	Brown	Bias on Coax/Fused
2	Seq. Step 2	High (750mA)	Open	Red	
3	Seq. Step 3	Low (100mA)	Open	Blue	
4	GND			Green	For Sequencer
5	GND			White	For Sequencer
15	GND			Black	For Sequencer
6	PWR ON	Active High		Gray	#6 of C232 HM Adapter
7	EXT LNA ON	Active High		Purple	#7 of C232 HM Adapter
8	TX EN	Active High		White	#8 of C232 HM Adapter
9	Not Assigned			Blue	#9 of C232 HM Adapter
10	GND			Black	#10 of C232 HM Adapter
11,12,13,14	Open				

Note: To Bypass Remote operation apply TTL High signals (+2.7-15V DC) to pins 6, 7 and 8 for their respective functions listed above.

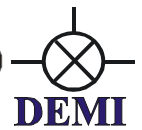
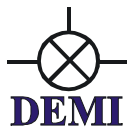

DEM LDPA COMPONENT LIST

Resistors (R) values are in Ohms.

R1 5.6	R13 10K	R25 10K	R37 2.7K	R49 1K
R2 15	R14 1M	R26 10K	R38 1KPOT	R50 10K
R3 51	R15 10K	R27 1M	R39 51	R51 10K
R4 51	R16 10K	R28 10K	R40 100	R52 1K
R5 51	R17 10K	R29 10K	R41 470	R53 10K
R6 220	R18 1M	R30 10K	R42 1K	R54 1K
R7 1K	R19 10K	R31 470	R43 1K	R58 10K
R8 470	R20 10K	R32 220	R44 1K	R59 1K
R9 51	R21 10K	R33 10K	R45 10K	
R10 51	R22 10K	R34 10K	R46 10K	
R11 10K	R23 1M	R35 220	R47 10K	
R12 10K	R24 10K	R36 22K	R48 470	

All capacitors (C) are in pF unless otherwise specified.

C1 27	C16 100	C30 100	C44 2.2uF
C2 33	C17 100	C31 100uF	C45 100
C3 27	C18 100	C32 100	C46 0.1uF
C4 220	C19 2.2uF	C33 0.1uF	C47 100
C5 100	C20 10	C34 100	C48 10uF
C6 2-6 TRIMMER	C21 18	C35 100uF	C49 22uF
C7 2-6 TRIMMER	C22 22	C36 2.2uF	C50 100
C8 0.1uF	C23 2-6 TRIMMER	C37 100	C51 0.1uF
C9 0.1uF	C24 22	C38 0.1uF	C52 100
C11 100	C25 18	C39 100	C53 0.1uF
C12 0.1uF	C26 10	C40 100	C55 100
C13 100	C27 100	C41 100	
C14 12	C28 100	C42 100	
C15 36	C29 0.1uF	C43 2.2uF	

All inductors (L) are in nH and 1008 chip unless otherwise specified. "PW"=pre-wound
"HW"=hand-wound using enamel wire

L13 3 Turns #24 3/16" dia HW	L19 82nh	L26 82nh
L14 5 Turns #24 3/16" dia HW	L20 330nh	L27 82nh
L15 5 Turns #24 3/16" dia HW	L21 120nh	L30 1.0 µH
L16 3 Turns #24 3/16" dia HW	L22 27nh	
L17 1.0 µH	L24 1.0 µH	
L18 1.0 µH	L25 1.0 µH	



Solid State, Relays and Filter Components.

CR1	MMBD914	IC1	RA80H1417M1	Q7	PMBT3904
CR2	MMBD914	IC2	PHA-1	Q8	MJD31
CR3	MMBD914	IC3	LM324	Q9	PMBT3904
CR4	MMBD914	IC4	LM3914	Q10	MJD32
CR5	MMBD3814	K1	G5V or equivalent	Q11	PMBT3904
CR6	MMBD914	K2	RG1ET	Q12	PMBT3904
CR7	MMBD914	K3	RK1	Q13	PMBT3904
CR8	MMBD914	K4	RG2E (Remote or Pre-Amp Opt)	Q14	MJD31
CR9	MMBD914	Q1	PMBT3904	Q15	PMBT3904
CR10	MMBD914	Q2	PMBT3904	Q16	PMBT3904
CR11	MMBD2800	Q3	MJD32	Q17	MJD31
CR12	MMBD914	Q4	PMBT3904	Q24	PMBT3904
CR13	MMBD914	Q5	PMBT3904	VR3	78L05
F1	FUSE (Remote or Pre-Amp Opt)	Q6	FPD750	VR4	78M05



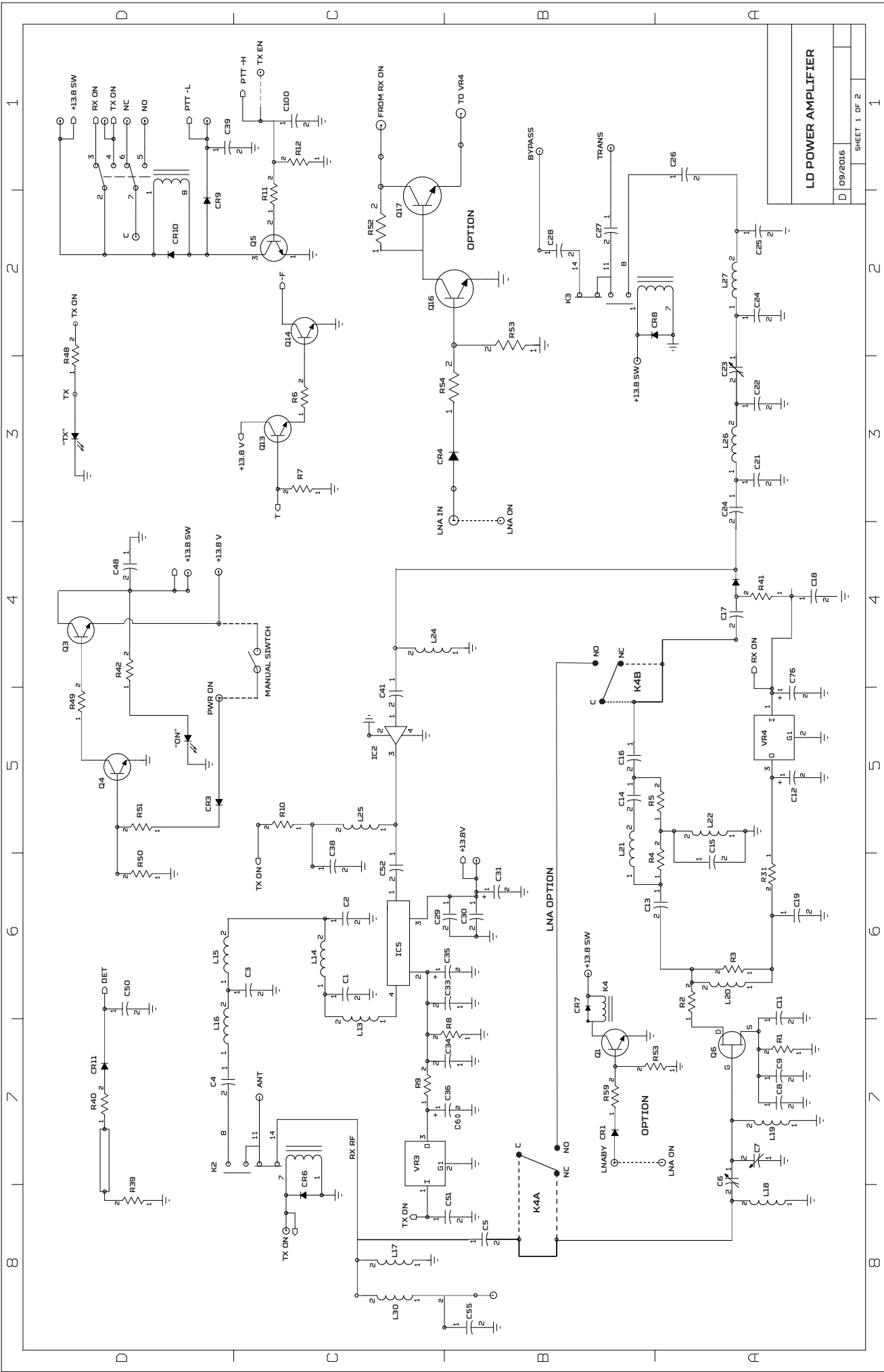

LD POWER AMPLIFIER

D 09/2016
SHEET 1 OF 2

1 2 3 4 5 6 7 8

D C B A

