



DEM Part Number 3456-144 _____
9 cm Transverter Serial Number _____

Specifications

Frequency after 10 Min warm-up:	3456.100 MHz. = 144. _____		
Noise Figure and Gain:	1.9 dB nom. > 17 dB Gain		
Power Out:	20 mW	1 W	Other _____
DC Power Requirement:	10 - 15.5 VDC @ 1 Amp		
IF Option:	Common	or	Split
IF Drive Level Requirement Option:	10 mW	1-10W	Other _____
Keying Option:	PTT - to ground		TTL - Positive Voltage
Aux. Connection Output Option:	Ground on TX	+ Voltage on TX _____	
TR Switching Option:	None	Installed	Supplied

Operating Instructions:

This DEM 3456-144 transverter is a combination of circuit boards designed by Down East Microwave Inc. All circuitry operates from a internal 9 VDC Regulated supply which makes it an ideal portable rig or it can be easily implemented into an existing home station. Please review all options installed in this transverter before interfacing to a standard 2 Meter IF rig. Interfacing can be simplified by using one of the various interfacing options available from DEMI or simply configure your 2M IF rig yourself to correspond with the options installed in the transverter. If you are unsure of the options installed or of the correct way to interface your 2M IF rig, please consult DEMI to avoid unnecessary damage to your transverter.

A block diagram is supplied to show the DC wiring of the transverter and the interfacing of the various circuit boards used in the transverter. This is provided for information and location of adjustment points to aid in your station integration. This will also aid you if you decide to add a pre-amp, power amp, T/R switch or sequencer to your system or to install or disable the various available options. Schematics and circuit board diagrams are also provided for all of the internal electronics.

Once all interfacing is complete, operation is simple. Please note frequency calibration listed on the top of this document. Remember the transverter should always be "hard-keyed". It is **not RF sensed**. If your 2M IF rig does not have an external keying line (Push to Talk to Ground, PTT or Positive Voltage on Transmit, TTL) you will need to install one. You should consult your manual or the manufacture for details.

Output power levels, receive gain and frequency may be adjusted internally by removing the top four screws and opening the cover. Be careful because the local oscillator is attached to the top cover and is connected to the main transverter board by coax and DC power connection.

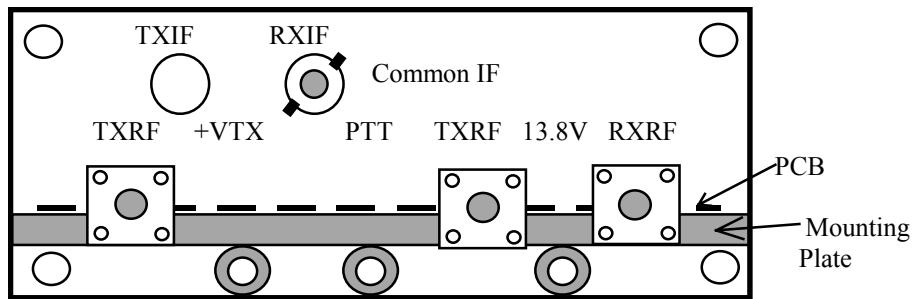

Rear Panel Diagram

The 1 watt output version will have a extra SMA connector installed. The TXRF connector will be mounted by the RXRF connector so that a common SMA type relay may be connected to perform the TR function. The connector in the old TXRF position will be a dummy connector and will not be connected to any circuitry.

Enclosure and PCB Mounting

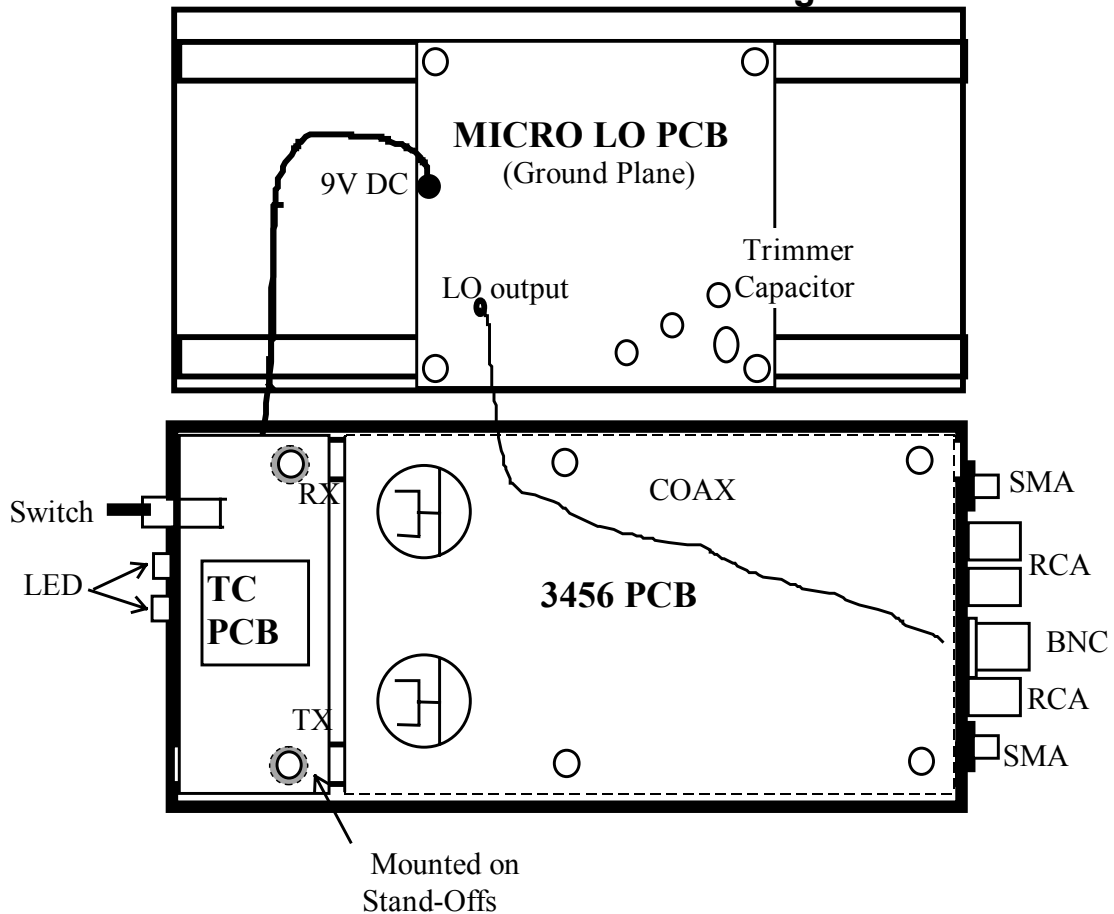

Enclosure and PCB Mounting

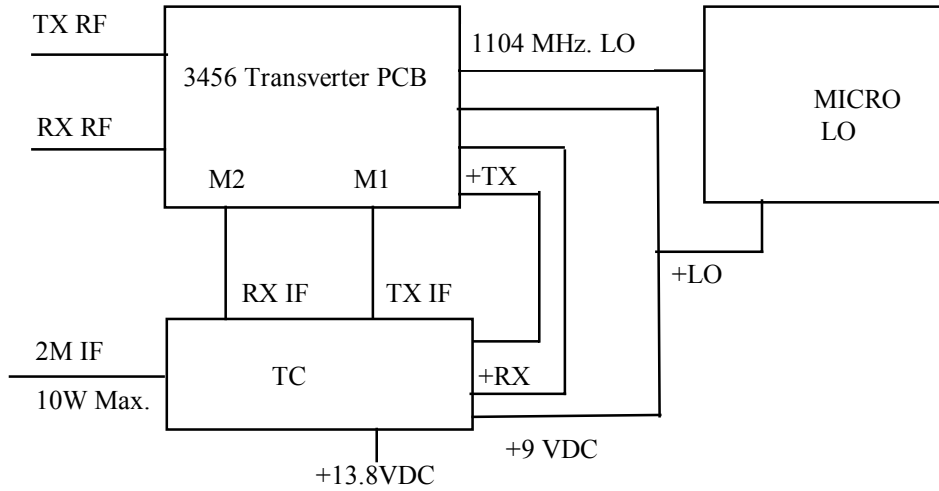

Wiring Block diagram

3456 Transverter Board Parts List

All components are Surface Mount components unless otherwise noted.

C1	8.2 pF ATC	C12	0.1 μ F	C23	10 pF	R7	130 Ω	U4	ERA-1
C2	0.1 μ F	C13	0.1 μ F	C24	10 pF	R8	150 Ω	U5	ERA-2
C3	10 pF	C14	10 pF	C25	0.1 μ F	R9	10 Ω	U6	ERA-1
C4	0.1 μ F	C15	0.1 μ F	C26	0.1 μ F	R10	130 Ω	U7	ERA-1
C5	0.1 μ F	C16	100 pF	C31A	10 pF	R11	10 Ω	U8	SGA-6286
C6	100 pF	C17	0.1 μ F	R1	10 Ω	R13	130 Ω	CR1	MA4E2054B
C7	10 pF	C18	10 pF	R2	51 Ω	R14	130 Ω	CR2	MA4E2054B
C8	0.1 μ F	C19	0.1 μ F	R3	130 Ω	R15	130 Ω		Optional – ERA-1
C9	10 pF	C20	0.1 μ F	R4	130 Ω	U1	MGA86576		Optional – 200 Ω
C10	0.1 μ F	C21	0.1 μ F	R5	51 Ω	U2	ERA-1		Optional – 130 Ω
C11	10 pF	C22	100 pF	R6	130 Ω	U3	ERA-1		

3456-144 PA SECTION

C27	0.1 μ F	C32	10 pF	C36	10.0 μ F	R19	51 Ω
C28	10.0 μ F	C33	10 pF	R16	51 Ω	ICL	7660
C29	0.1 μ F	C34	0.1 μ F	R17	10K POT	Q1	FLL 177
C30	10 pF	C35	10.0 μ F	R18	1 Ω 1W		2- Sets of 2-56 (screws and nuts)
C31B	10 pF						



Operating and use tips:

1. You will need to hard-key this transverter. It is not RF senesced! If you wish to have your transceiver key the transverter, you will need to use the auxiliary contacts or a positive voltage on transmit generated by your IF transceiver.
2. The transverter will accept a maximum IF drive level of what is indicated on the front page. If the 10 watt IF drive version is ordered, a maximum of 25 watts may be applied momentarily without causing damage to the transverter. If you wish to use a transceiver with an output power greater than 10 watts, you will need to supply additional attenuation. A receive IF gain stage may be added to the TC board to compensate for the additional attenuation. See that enclosed document for details.
3. RX and TX levels may change slightly after adjustments when the enclosure is re-assembled.
4. Frequency of the LO will change over time. The more "Burn in" before actual use, the better!
5. Frequency drift will be minimal after a 2 minute warm up and drift free after 10 minutes unless the enclosure is located in a inconsistent airflow environment.
6. Be sure to use high quality coax for all connections
7. This unit may be mast mounted but it is not weatherproof. Simple protection from the rain is all that is required.



DEM TC DEM TRANSVERTER CONTROL

The DEM Transverter Control (DEM TC) is the circuit board that controls all transverter functions in the DEMI 2.3 GHz. -10 GHz. transverters. It was designed with many options and depending on the configuration you have ordered (see configuration page of main transverter document), the options may or may not be enabled in your transverter. This document will cover all of the features available for understanding and make it possible to change the configuration at any time to suit your requirements.

Circuit Description: (All functions mentioned may or may not be enabled in your transverter)

The DEM TC circuit board is mounted in the front of the transverter. It includes the DC power switch and both the "Power On" and the "Transmit On" LED's. The TC contains a 1.5 amp, 9 Volt regulator that supplies the transverter with all of the regulated DC voltage it requires and allows some head room for other external circuits. The TC controls all of the IF switching functions utilizing a high isolation RF relay that is rated through 1 GHz. It allows the use of any frequency of IF up to 1300 MHz. On transmit it will allow the use of up to a maximum of 10 watts of drive depending on configuration. The TC also incorporates adjustable attenuators for both transmit and receive and has a provision for adding additional receive IF gain. The TC allows either a PTT High or Low for keying the transmit and receive circuits. Another feature included on the TC circuit board is a 24 Volt relay driver designed to operate most SMA relays used for Transmit and Receive switching of the RF frequencies. This circuit may not work with certain types of relays but will operate with any SMA relay supplied by DEMI. Other options include different auxiliary DC switching schemes, keying the transverter through the IF coax, and supplying PTT keying signals to external equipment. Connection and use of each circuit is explained below. Refer to schematic and component list for all component designations.

RXIF Gain and Adjustment:

The installation of the receive IF gain stage is the most asked about device in the transverter. If the transverter is to be installed at the antenna with a long run of coax for the IF line, you may wish to install IC1. Understand that installing this gain stage will not improve the system noise figure and in most cases it will slightly degrade it. If you wish to improve the system noise figure, you should add a LNA at the RF frequency. Then depending on the gain of the additional RF LNA, you may not need the RXIF gain stage even if the transverter mast mounted. If you wish to install IC1, refer to the component placement to determine where it is installed along with its bias resistor R9. Any low frequency MMIC may be used but select it for the correct amount of gain required. Also consider the noise figure unless you have a RF LNA in the system. Select the value of R9 for the MMIC to be used for 13.8VDC operation. To bypass the gain stage, install a leaded 120pF capacitor in place of IC1. Keep the leads short.

The RXIF gain can be adjusted with R7. There should be approximately 20 dB of range. With your system completely connected, R7 may be adjusted to an acceptable level determined by your ear. For best results, keep the gain to a minimum. Only a slight noise increase should be noticed by cycling the power switch of the transverter. If your "S" meter of your IF radio is at half scale, you have lost half of the dynamic range of your system. For the same reasoning, adding the gain stage and then adjusting the RXIF to maximum will degrade the dynamic range further.



TXIF Drive Level and Adjustment.

The TXIF drive level adjustment (R2) has approximately 20 dB of range. Depending on the configuration ordered, this adjustment range may not be acceptable. If so the fixed attenuator may need to be installed, removed, or adjusted. If you wish to use less than 50 milliwatts of IF drive power, install a short jumper wire in the R4 position and remove the large 50 ohm termination that may be installed on the front panel. If you wish to use up to 2 watts, install R4 as shown with the large 50 ohm termination. If you plan to use 1 - 10 watts of IF drive, install a 1pF capacitor in the R4 position with the 50 ohm termination. If you need to experiment with other drive levels, any combination of variable capacitor or resistor may be used in the R4 position. You may also adjust the values of R1 and R3 as needed. Input power to the TXIF adjustment is dependent on the attenuation installed on the C3 side of the K1 relay. The 50 ohm load resistor is designed to handle 35 watts with proper heat sinking. When mounted to the front panel of the transverter, it will not tolerate more than 10-12 watts reliably for a long period of time. You may experiment with external heat sinking if you desire. External attenuation may also be used in the transceive path. Remember that the added attenuation is also on the receive signal but may be overcome by the additional gain of the RXIF gain stage. The level then may be adjusted with the RXIF adjustment.

Split Transmit and Receive or Common IF Configuration:

If you wish to use your transverter with separate TX and RX ports, first remove C3 and C5. Then attach coax from the IF connectors to the corresponding TXIF and RXIF connections at the C3 and C5 locations. If you are converting a split IF to a common IF, C3 and C5 may or may not be already installed. Select the coax you wish to keep as the common and connect it to the common input of K1.

PTT-H and PTT-L

The TC has the option of either using a PTT-H or PTT-L keying circuit. The PTT-H requires +1.5 to +18VDC to activate it and will sink up to 2 mA. If using this circuit, be certain that the sink current will not exceed your transceivers rating. The PTT-L circuit requires a connection to ground to be activated. It is connected to the K1 relay and will source up to 25 mA to ground when keyed. If this exceeds your transceivers rating you may modify the TC as shown in our design note DN0?? Found in our library on our web site or call for a copy.

PTT Keying Through the IF Coax:

Some transceivers such as certain models of the Yeasu FT290 supply a positive voltage on it's RF output connector during transmit or receive. This voltage may be used for keying the transverter. After verifying or modifying your transceiver for this function, the transverter may have the option installed. Select a choke of 1.0 μ h or larger and install it in the L1 position of the TC. Then connect a short wire jumper from the DC side of L1 to the PTT-H connection. When the transceiver is keyed, the voltage in the coax will key the PTT-H of the transverter. This is the most fool proof connection of the PTT line that can be made with any transceiver and is highly recommended by DEMI.

If the PTT-L connection is connected to the PTT connector, it will not affect the operation of the system. Just do not key both lines at the same time! If you will never use it, it may be disconnected and the external connector may be used for any other auxiliary connections.



+DC Switching Functions:

Relay K2 controls all of the +DC switching functions in the transverter. One side of the relay switches the raw +DC supply voltage to the transverter and the other side switches the regulated +9 volts. There are extra connection holes on the PCB if you require any additional switched voltage. Be sure not to exceed the 1.5 amp limit on the 9 volt regulated supply. The transverter's current drain is listed on its configuration page and allow for some overhead when the oscillator is not warmed up.

The switched voltages may be used for external LNA's, switching circuits for power amplifiers or relays. You may need to add an extra hole for a connector if the AUX connector is used. Be sure to fuse any external connections. The relay's contacts (K2) are rated for 3 amps.

24 Volt Relay Driver:

The TC is designed with a 24 Volt relay driver. A brief explanation of the circuit is as follows. When the TC is in the receive mode, a 330 μ F capacitor is charged to the raw input voltage of the transverter (12-14 VDC). When the PTT circuit is activated, K3 switches this charged capacitor in series with the TXON voltage and outputs a brief spike of 24-28 VDC at the +R connection on the TC board. Depending on the current drain of the connected circuit (or relay), the charged capacitor bleeds off down to the raw input voltage of the transverter. The spike is enough to energize most SMA relays and the raw transverter voltage is enough to keep the relay energized. This circuit will not work with all relays but will operate with all relays supplied by DEMI in the optional WTR kit. If you wish to use a relay with a higher current drain, the 330 μ F capacitor may be increased. Just be sure that the relay being used will stay energized with +12 VDC. This circuit will not operate latching relays unless additional circuitry is installed.

PLEASE NOTE! Even though this connection will bleed down to the raw voltage of the transverter, the circuit should never be used on any electronic circuit that will not tolerate a **+28VDC input!** It will damage most +12VDC circuits. It will also not operate any circuit requiring voltage greater than the transverter's supply voltage other than a relay.

If a switched +VDC is required, move the wire from the +R connection (if installed) to either the +VTX, +RX, +9, +13RX, +13TX, or +13.8SW. Refer to the schematic for their functions.

RF Sensing Transverter Keying

The TC is not designed to be a RF sensed switch. It has 3 relays and it may be connected to external mechanical relays. If any RF sensing scheme is added to the circuit, it will cause excessive relay chatter that will not only wear out the relays prematurely, but could cause other failures to external preamplifiers and or power amplifiers if used in your system. RF sensing circuits are not recommended with any circuit the contain mechanical relays at RF frequencies!!



DEM TC Component List

C1 0.01 μ F	C10 2.2 μ F elect.	Q1 PN2222	R9 330 Ω
C2 0.01 μ F	C11 2.2 μ F elect.	R1 220 Ω	R10 5.1K Ω
C3 0.01 μ F	C13 330 μ F elect.	R2 1K pot	R11 5.1K Ω
C4 0.01 μ F	D1 -D6 1N4000	R3 220 Ω	R12 330 Ω
C5 0.01 μ F	IC 1 MAR6 ❶	R4 220 Ω ❸	2 - Red LED
C6 0.01 μ F	K1 G6Y relay	R5 1K Ω	VR1 78S09
C7 0.01 μ F	K2 G5V relay	R6 220 Ω	50 Ω load
C8 0.01 μ F	K3 G5V relay	R7 1K pot	1 pF ❸
C9 100 μ F elect.	L1 1.0 μ h ❷	R8 220 Ω	

- ❶ To by-pass IF gain stage, install 120pF in place of IC1.
- ❷ L1 is used with transceivers that have + DC voltage on RF line during transmit
- ❸ Depending on the drive level used, R4 may be replaced with a short, a 1pF capacitor, or a variable capacitor. See text for description.



DEM MICROLO Microwave Transverter Local Oscillator

Description and Operation:

The MICROLO is used in all of DEMI's line of microwave transverters (2304 and up) as the base frequency oscillator. Depending on the model of transverter you have, the table below will provide crystal information and multiplication factors for all. The frequencies listed in the Model column are the standard "Weak Signal" RF operating frequencies. Your transverter may be configured for other RF and IF frequencies than listed below but will be indicated on the configuration page of the main transverter document.

Model	Crystal	LO Output Frequency and Output Power	Multiplication	Xverter LO Frequency
2304-144 MHz.	180.000 MHz.	1080.000 MHz. +3dBm	X2	2160.000 MHz.
3456-144 MHz.	184.000 MHz.	1104.000 MHz. +3dBm	X3	3312.000 MHz.
5760-144 MHz.	187.200 MHz.	1123.200 MHz. +3dBm	X5	5616.000 MHz.
10368-144 MHz.	189.333 MHz.	1136.000 MHz. +3dBm	X9	10224.000MHz

If you encounter any problems relating to the MICROLO, refer to the DC checklist, and with a voltmeter, find the test points on the component placement and schematic. Then proceed to verify all six test points. All voltages are referenced to ground. The MICRO-LO is supplied by the +9 VDC voltage from the TC board. Verify all +9VDC connections first.

Voltage test points

Test junction point	Voltage	Test junction point	Voltage
Input of IC1 - IC4	2.0V ± 0.75	Output of IC1 - IC4	5V± 1 V
Junction of Q1 - C3	5V ± 0.2	Junction of R1-C1	1.8V± .5
Junction of R5 - Q2	0.8V ± 0.3	TP1	> 0.7V

If troubleshooting the MICROLO, be sure the voltage at TP1 is peaked by adjusting C2. This will assure the best performance of the MICROLO. If you have a frequency meter, the frequency may also be adjusted with C2. Although this is an acceptable way of "Netting" the frequency, any adjustment other than a voltage peak at TP1 may result in a oscillator that will not start when cold, drift, or have low output power.

If any of the test voltages cannot be obtained on IC1 - IC4, understand that MMICs may sometimes operate out of specification. The important thing in troubleshooting is that all MMICs draw current when working correctly and have something other than the supply voltage or a short to ground on both Input and output.

Changing the Crystal in the MICROLO:

If you decide to change the operating frequency of your transverter, install the new crystal exactly the same way as the original crystal. Before installing the Thermistor as shown in figure 1., verify that the MICROLO operates with the new crystal first. If the voltage peaks and the frequency can be “Netted”, attach the Thermistor and ground wire. To assure frequency stability over time, allow the LO to operate for 1 hour with the Thermistor in place before adjusting the final frequency. In real time operation total warm-up should be no more than 5 minutes maximum after the first hour of operation.

After a new crystal installation and a minimum of a 1 hour “Burn-In”, you may encounter difficulty netting the frequency. If so, please consult our Design Note # 016 found in the Down East Microwave web site library or call for a copy. It reviews a procedure that requires a circuit modification and adding a chip capacitor.

MICROLO Parts List

All capacitors are chips and are pF unless otherwise noted. White Band is Positive on 1.0 μF. All resistors are in ohms. The coils are formed using #24 enamel wire.

C1 0.01μF	C10 0.1μF	D1 HSMS2800	R3 1K	VR1 78L05
C2 1-8 Piston	C11 22	L1 3T 1/8" ID	R4 100	Y1 CRYSTAL
C3 0.01μF	C12 15	L2 0.1μH molded	R5 51	IC1 MAR-3
C4 18	C13 15	L3 6T 1/8" ID	R6 100	IC2 MAR-1
C5 22	C14 0.1μF	L4 4T 1/8" ID	R7 100	IC3 MAR-1
C6 1.0 μF	C15 22	Q1 2N5179	R8A,B 220	IC4 MAR-3
C7 1.0μF	C16 0.1μF	Q2 2N5179	R9 180	PTC-Thermistor
C8 0.01μF	C17 0.1μF	R1 560	R10 180	Micro-LO PCB
C9 0.1μF	C18 22	R2 1K	R11A, B 220	

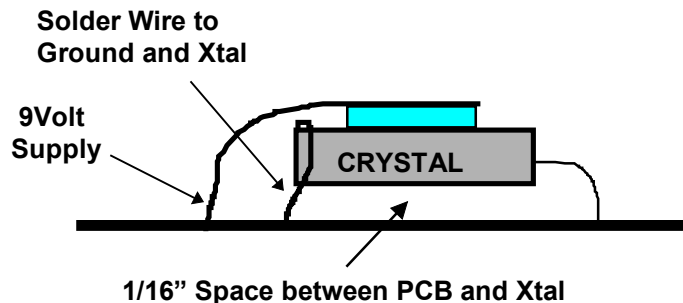
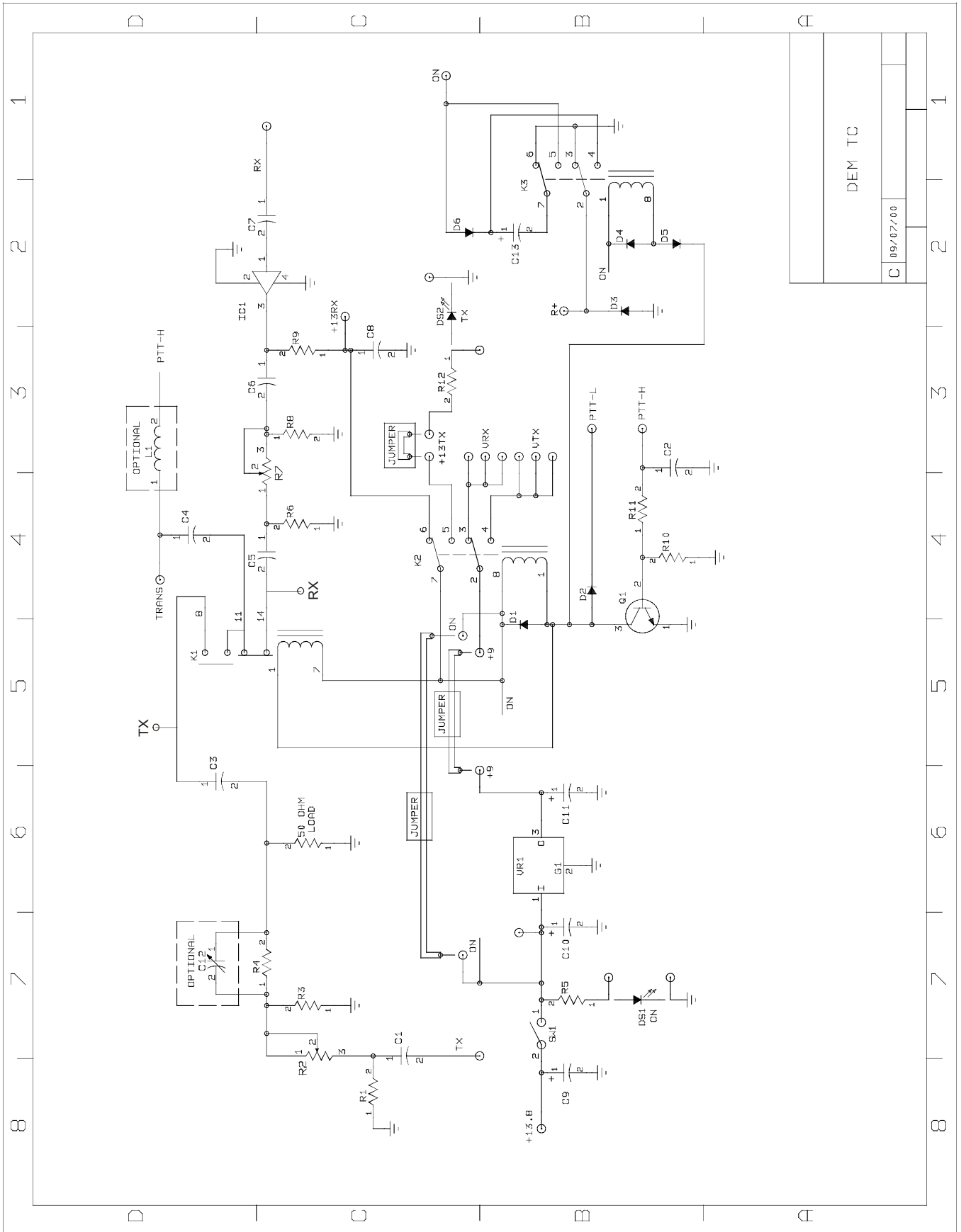
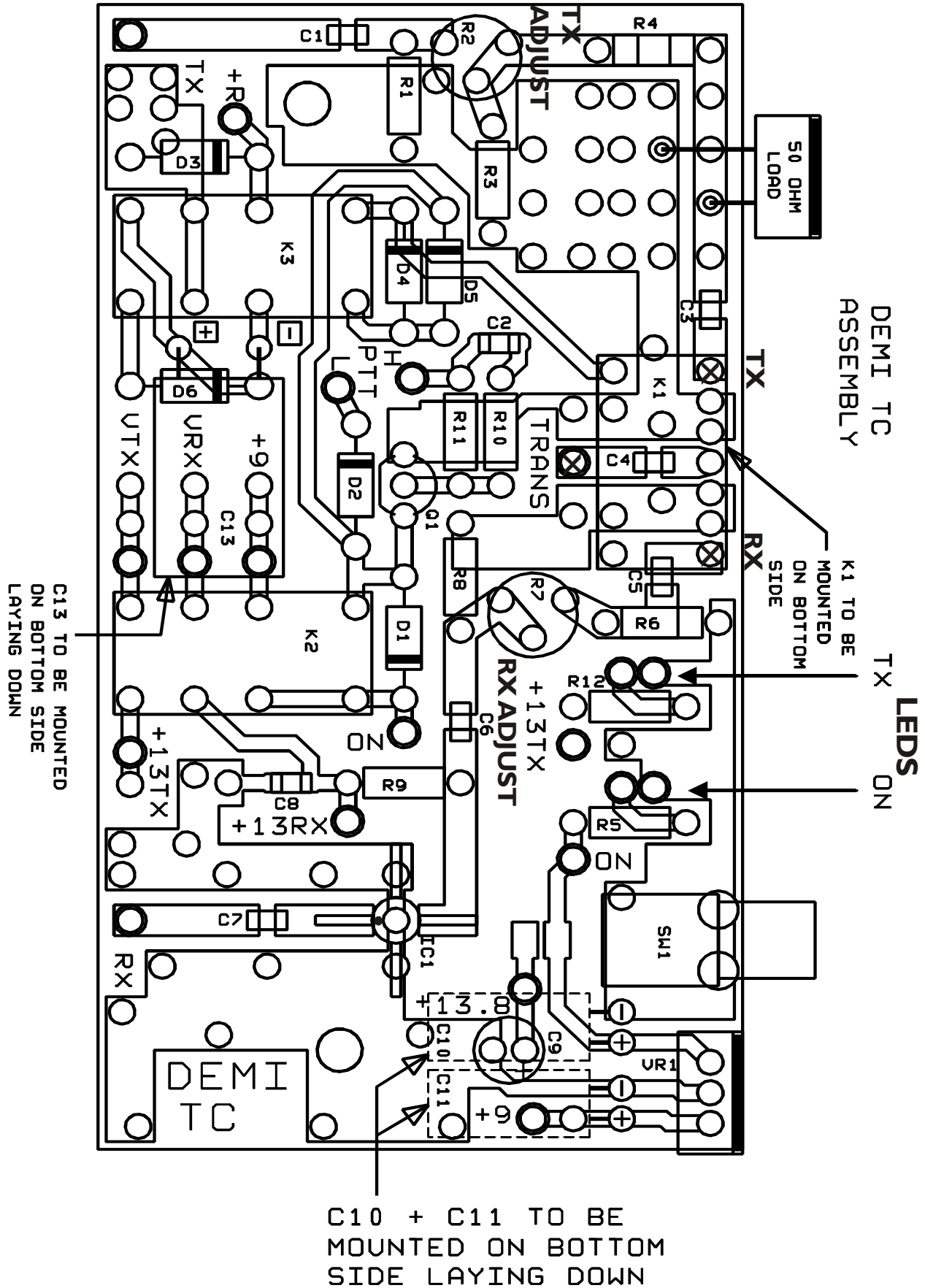
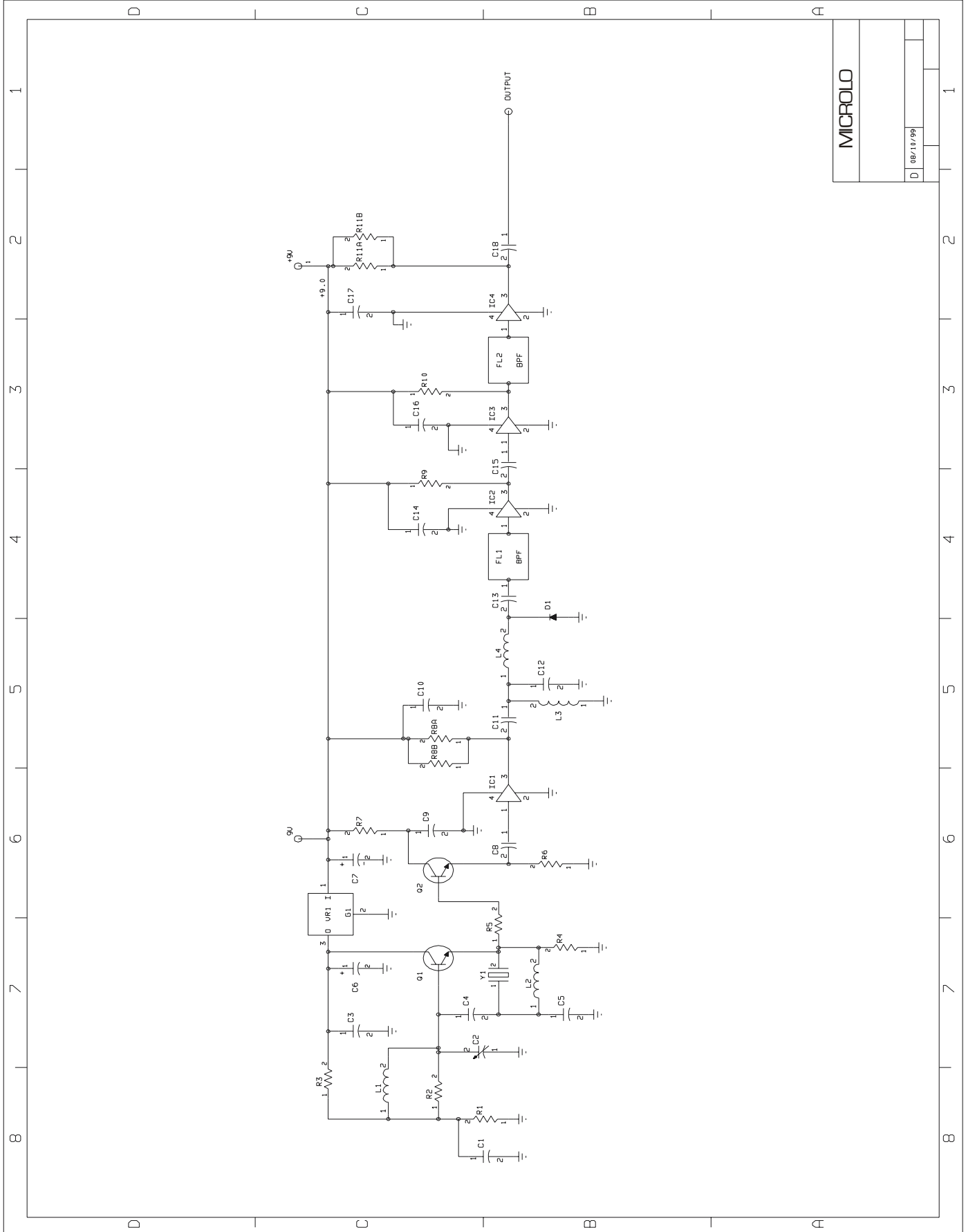

Figure 1. Crystal and Thermistor Installation details.



DEM TC	
C	09/07/00







DEM MICRO LO

BOTTOM SIDE ASSEMBLY

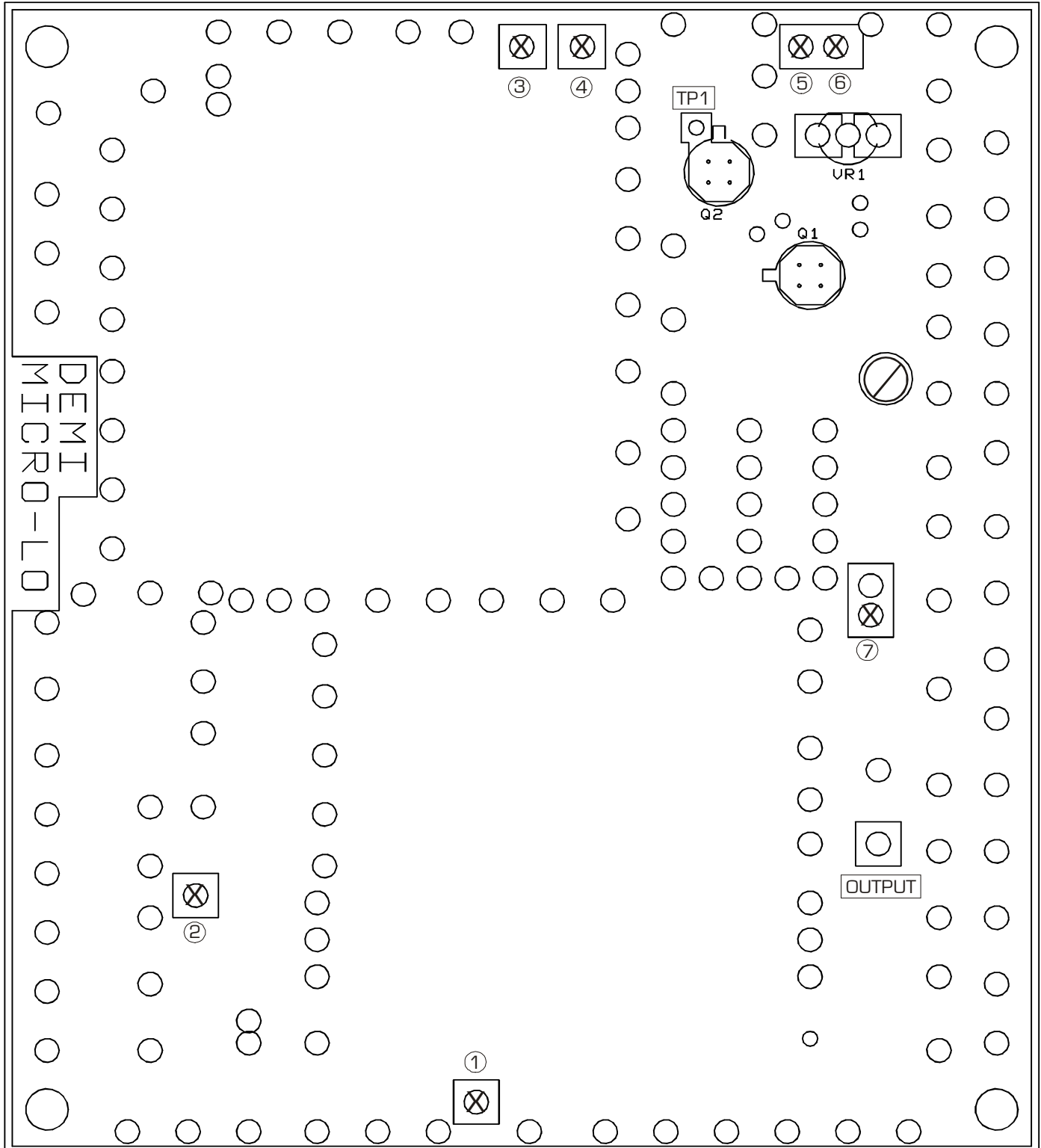



DEM MICRO LO

TOP SIDE ASSEMBLY

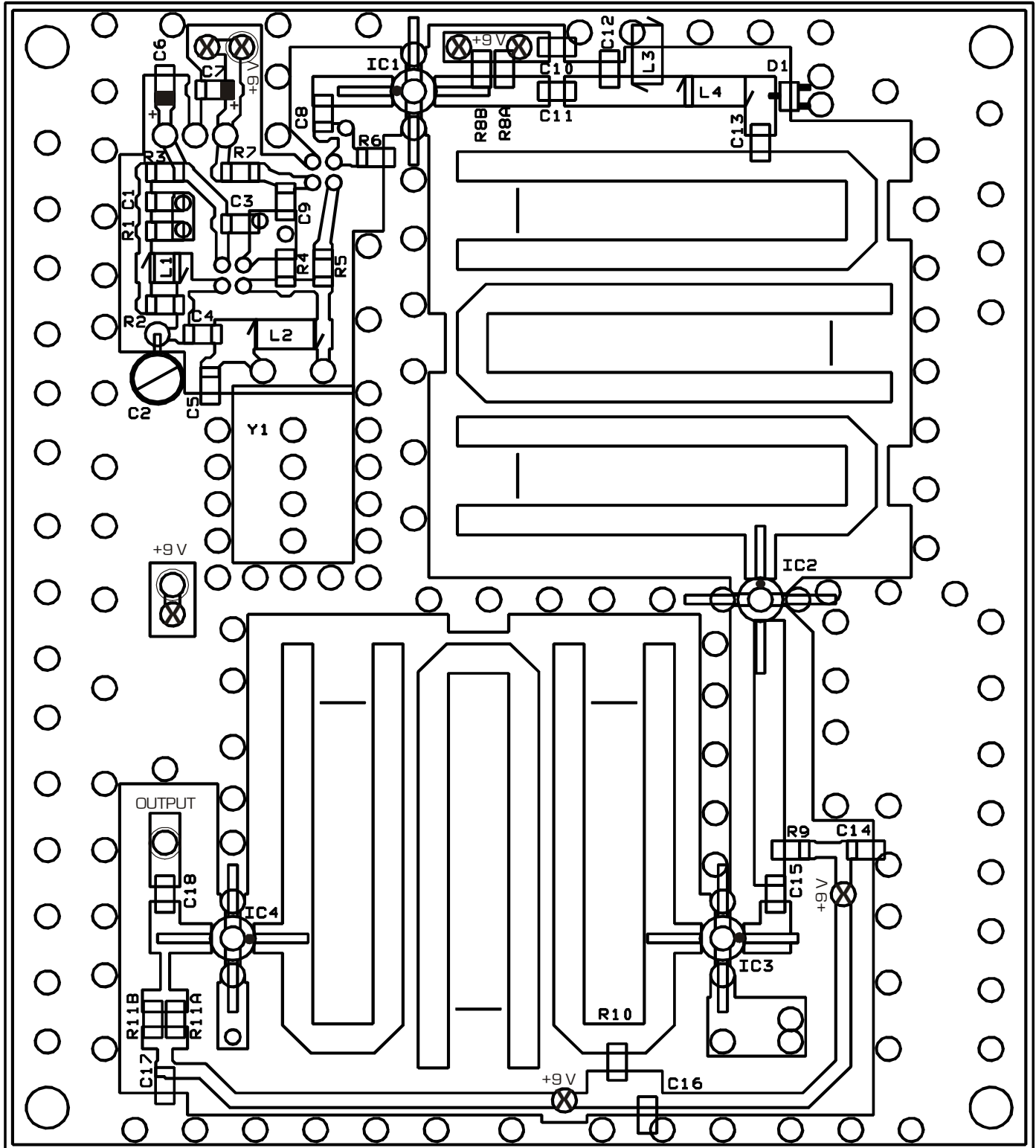

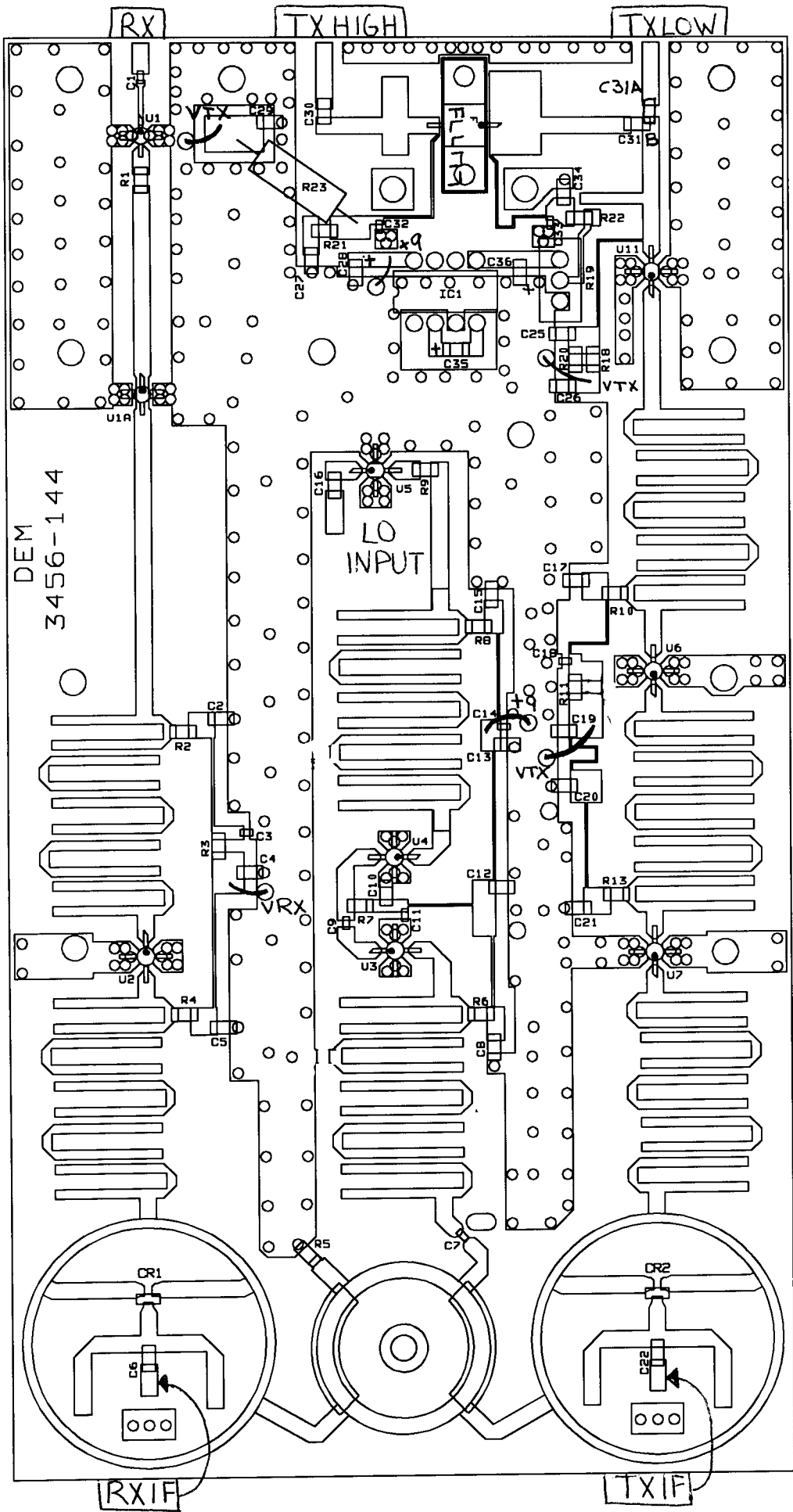

DEM
3456-144

RX

TX HIGH

TX LOW

LO
INPUT

RX IF

TX IF