

DEM Part Number 5760-144K, CK and 5760-144LPK and CK 5.7 GHz. Transverter, Low Power Transverter, Kit and Complete Kit

Specifications

Frequency:	5760.000 = 144.000 standard	
Noise Figure and Gain	< 1.5 dB NF, > 17 dB G	LP: < 3.5 dB NF, > 17 dB G
Power Out	> 3 Watts.	LP: >10 mw
DC Power	11-16 VDC @ 2.5 A	LP: < 600 mA
IF Power Input (144MHz)	1 mw min. to 10 W max. Adjustable	

Preliminary:

The 5760-144CK and 5760 -144LPCK is a complete kit version of the 5760-144 and the 5760-144Low Power transverter. In our Complete Kit version, you receive all 3 circuit board kits, the 5760K, (transverter PCB) the TC and the MICRO LO with a prepped extruded aluminum enclosure, mounting plate, and all necessary hardware and connectors to get you on the air. When completed, you will only need to supply a TR switch, Antenna and a 2 meter transceiver. The 5760K is a PC board kit designed by W1GHZ and Down East Microwave Inc. When W1GHZ (ex N1BWT) first designed and released the details of this transverter in NOV. 1997 QEX, it was a basic PC board design with some details of how to interface it with a few circuits to produce a simple state of the art transverter. DEMI has refined the design and produced a one basic PCB Kit (low power) and two Complete Kits (low power and 3 watt version) with all of the interfacing required. It is recommended by DEMI (but not required) that you obtain the mentioned QEX article and read it. It will provide some technical details such as design criteria and additional interfacing not covered in this Kit assembly manual. This article also describes a power detector that is a minimum requirement for testing this transverter. We recommend that you have a Microwave milliwatt power detector of some type as a minimum for proper alignment.

In this transverter, the DEM TC is the interface circuit board that allows the use of up to a 10 watt 144 MHz transceiver. It contains TX and RX level adjustments. It provides all of the DC and RF switching functions for the transverter actuated by it's keying circuit that is either PTT-L, (to ground) or PTT-H, (+ voltage) on transmit. It also supplies all internal biasing of the transverter and external switching functions for TR switches, PAs, and LNAs. It also contains a 9 Volt 1.5 amp voltage regulator to supply the regulated DC power to the transverter.

The MICRO LOK local oscillator kit provides a nominal +3 dBm output at 1123.200 MHz. for 144 MHz IF operation. The transverter PCB accepts the LO input and multiplies it to 5616 MHz. A test port for tune-up and testing the 5616 LO before the signal is injected into the mixers is available on the transverter board. The 5760 MHz. signals are tested through 2 separate type SMA connectors, TX and RX. The TX and RX connectors are spaced correctly to allow a direct connection of common SMA relay to complete the system and allow the use of a common antenna connection.

This assembly manual assumes that the complete kit version (5760-144CK or 5760-144LPCK) is being assembled but is also used for the 5760K, the PC board kit version. Use what is required from this document for the different assemblies.

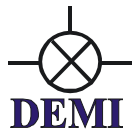

Options:

There are no assembly options for the 5760 transverter board detailed in this manual. You are limited by the transverter's PCB and supplied components of what version you can assemble. The manual will describe one way of assembly that will produce a state of the art 5760 MHz. transverter of choice. If you wish to experiment with different gain stages and add-on filters and amplifiers, do it with caution. Modifications should not be attempted without test equipment that will provide accurate power levels and a spectrum analysis. DEMI will be more than happy to consult you with any of your modifications, but will only assume full responsibility for this design if you use the supplied components and assembly procedure. If you decide to stray from the original design, or assemble the 5760 PCB with your own components, you will assume the responsibility of the results. We will answer any questions you may have **but a repair and/or alignment by DEMI will only occur if the transverter kit is in stock form!** If you have any questions about this policy please consult us first before proceeding with your own design or modification.

Assembly:

The TC should be assembled first per its assembly document. Some general assembly options may be implemented to it depending on your requirements. The DEM TC has provisions for an extra RXIF gain stage that may be required if you chose to tower mount the assembly or use a large attenuator with a high power 144 MHz transceiver. The TC allows a 1mW to 10W common or separate IF input that will require the proper configuration. It's your choice. The regulated or unregulated voltage is switched to supply any additional stages such as a LNA or power amplifier or the PTT circuit may be mirrored or inverted. The standard document of the TC has many more details concerning its various options of operation. Please follow it for assembly and for the completion of the complete kit version of the 5760-144 or 5760-144LP.

The MICRO LOK should be assembled next per its provided document and tested individually. The output of the MICROLOK should be +3 dBm (± 2 dBm) and is tested with a 9 volt supply only! It is designed to operate at 9VDC provided by the TC and includes a PTC Thermistor for frequency stability. If you have a different voltage requirement, all active devices will need to be re-biased. It will not work with +12VDC in its stock form!!! The ability to measure the output power of the LO is not necessary but is recommended.

When configuring your system, please note that DEMI can supply a few external options. If you require a "State of the Art" noise figure, a 5 cm PHEMT preamplifier designed by W5LUA can be purchased. It is part number 5LNAHK (board kit) or a complete kit version is 5LNAHCK. If you require more output power than the 3 watt version, and have access to the surplus market of 5 to 20 watt amps, be sure of the drive level of the amplifier. Most amplifiers may only require 10 mW of drive which can be easily provided by the LP version of this kit. DEMI also stocks relays, a basic sequencer and other accessories that will enable you to complete your 5760 MHz. station.

Transverter PCB Assembly:

1. Inventory the parts list. Every part in this kit is important and should be identified. There are extra chip components packed in the vials, so no need to count them just verify value. The hardware should be sorted and identified if included in your kit. There are some extras. But remember, **No substitutions!** Review the component list and component placement diagram. Read through all of the assembly steps, 1 - 14 identifying every component used. Now is the time to get familiar with the kit and verify it is complete. This will also ensure that you have the correct tools and supplies required to complete the project. It is also time to make the last minute decision on building the kit or not. A full exchange towards a assembled version will be provided if you do not go past this step. We want you to be on the band and operating not struggling to assemble

this because you were not aware of what is required to assemble and align a microwave transverter.----- Last chance? OK, Lets Go!

2. Start by examining the circuit board for irregularities. During the drilling and plating process, plating or debris may fill the filter probe holes and prevent the pins from being inserted. It is simple enough to use one of the pins (extras provided) and push it through all of the filter probe holes to be sure it clears. We have found that pushing them through from the ground plane side works best. **Do not make the holes larger.** Just be sure the pin fits in all of the holes and they are clear. Also look very closely for shorts from the pinhole to ground. After the pipe caps are soldered on, it's too late to remove a short! Now check the TXIF and RXIF holes in the mixer (by D1 and D2) and the LO IN connection. These will be coax connections so also be sure of shorts or hole blockage with a silver pin.

3. Now inspect the MMIC mounting holes. The holes are plated. The PCB manufacturing process that provides us with the best grounding for the MMIC's, sometimes leaves a little extra metal deposited where it will cause harm. Depending on the registration of the circuit board, the plating may creep up over the edge of the hole. If the MMIC is placed in a hole like this, it will short the input and output leads to ground. Look for a shiny rim circling the hole. If visible, (it may be hairline thin) remove with a sharp knife. Only remove the metal where the input and output leads of the MMIC's may touch. **Do not remove the plating from the MMIC mounting hole that is connected to the topside ground pad!** Just touch up the imperfection with a knife when and where needed. See pictorial for clarity.

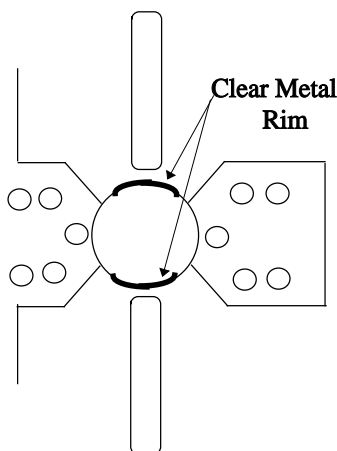
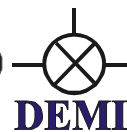

Figure 1. MMIC PC Board hole with metal rim

4. Install the PCB to the mounting plate. Place the ground plane side on the pallet and line up the holes. It only fits one way. Use the 4-40 x 3/16" screws but do not tighten the screws. The clearance holes in the PCB are purposely made larger so the board can move around slightly on the mounting plate to allow proper alignment of the SMA connectors and filters. Trim the Teflon insulator off of one SMA connector. Then examine the flange of the connector. Only be concerned with the surface that mounts to the plate. If the plating is rough or has a bur on it, use a file to remove and make smooth. Then trim the center pin length to approximately 1/16". Remove all rough edges from the pin. Using the short 3-48 screws, install the connector to the pallet on the LO test point. Refer to the component placement. Now, you may find that there is excess material



on the edge of the circuit board. This becomes evident when the connector cannot be mounted flush. Cut the excess material off with a sharp knife being careful not to cut into the plated metal. You may use the pallet as a guide. Tighten the SMA screws in place. If you need to readjust the SMA connector position, do so. Having proper alignment of the connector and the PC board mounting screws ensures that the filters will be correct. Tighten a few circuit board screws and check for alignment again. Repeat the process until all screws are tight and the SMA pin is properly aligned. Now install the two 4-40 x 9/16" screws, the 1/8" spacers and two 4-40 nuts in the clearance holes on the back corners of the circuit board. The head of the screw belongs on the pallet. The spacer is between the PCB and the nut. Tighten them and recheck all circuit board screws. Remove the SMA connector and then trim all of the excess circuit board material flush with the edge of the pallet on all four sides. Try not to cut into the ground plane. If you find the knife do so, you can loosen all screws and re-center the PCB to the pallet. When complete, the board edge will now act as the alignment if the circuit board is ever removed from the pallet.

5. It is now time to prep the pipe caps. All pipe caps have been drilled and tapped to 8-32. Check the inside for burrs and clean all excess lubricant with a cleaning solution. With an abrasive cloth, (sandpaper, Scotch-Brite™) buff -up the open end of the pipe cap, both inside and outside. The shinier, the better the solder will flow.

6. If you do not wish to solder the pipe caps to the PCB, we can do it for you. Return the pallet with the PCB mounted to it (all of the screws!) and all of the **pipe caps** with \$35 USD which will also cover standard return shipping. Your pallet will be ready for assembly when returned!

To solder the caps requires a propane torch, (a standard solder iron will not do the job!) electronic grade flux (liquid or paste) and electronic grade solder. **Do not use a Acid base flux or solder!** Even if you clean the acid flux off of the outside when finished, you cannot clean the inside of the cap and the acid will destroy the board from the inside out.

Start by fluxing the open end of a cap and place it into a hole at the end of the pallet. Then heat the cap with the torch, being careful not to allow the flame to come in contact with the bare circuit board, until you can flow solder into the corners of the pallet hole around the pipe cap joint. Remove the heat. Repeat this process until finished.

Some Tips for soldering the Pipe Caps are not to flux all of the caps and place them in the pallet before soldering. The flux will dry out on the last caps before soldering and cause a poor solder joint. Do not install the screws in the cap before soldering. The heated gasses inside of the cap needs to escape. If you apply pressure to the pipe cap while cooling, be careful not to push the PCB away from the pallet. The excess solder will flow between the board and the pallet causing a "Bump" in the board. Although this is not a disaster, it will cause a problem when soldering the components to the circuit board.

7. At the factory, we use "No-Clean" solder exclusively. It disappears with heat without smoke. We never use any cleaning solution on our assembled products. The concern we have for kit builders is that after assembly of the pipe caps, excess flux and residue has migrated between the PCB and the pallet. Depending on the corrosiveness of the flux, this may be a potential problem. We suggest, if you feel that there could be a flux problem, removing the PCB from the pallet and cleaning everything completely. Then inspect the solder joints for completeness. Be careful not to flex the circuit board excessively. Also, as ugly as it may be, do not trim any excess solder or re-flow a filter when it is not mounted to the pallet. It may cause a misalignment and the PCB will not fit flush to the pallet when re-assembled. If you find a bad joint, re-assembly the PCB to the pallet

being sure that the PCB is mounted flat to the pallet before tightening the screws and re-flow the pipe cap. Then, remove the PCB assembly, inspect and clean.

8. Refer to the component placement diagram. Note that it shows all of the components that will be used in your kit, but may not depict actual relationship in size (3 watt or LP). For the actual assembly, you will need a large solder iron to flow the solder on the ground leads. We use 40 watt irons with 700 degree tips In the Down East Microwave Factory. We also preheat the pallet to about 25 degrees F above room temperature on a hot plate. You may do the same with whatever means of pre-heating you have including the torch you used for the pipe caps. If you can still handle the pallet after pre-heating, it could be hotter! The aluminum pallet will hold the heat for a while but re-heating may be required, depending on your soldering speed, to keep the solder flowing smooth. Be sure of the MMIC's alignment. Consult the component placement diagram with every installation. The MMIC's are very difficult to remove if installed incorrectly.

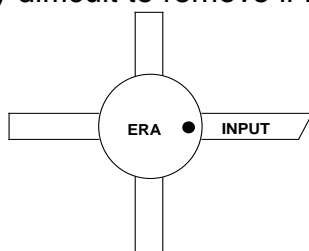

Figure 2. ERA MMIC, MGA86576 and ATF36077

When installing MMIC's make them as flat as possible. The bodies, except for U6 and Q1 will fit squarely in the PCB holes. (See addendum for installation of SMD MMIC's with preformed leads) Be sure to flow the solder on the ground leads up to the body of the MMICs. These leads need to be as short as possible to ground. If you can see the ground lead, it's not soldered correctly. Use minimum amounts of solder on the input and output leads but solder them as close to the body as possible. If you have a LP version, install U5-LP If you have the 3 watt version, install U5. U6 is installed on the surface of the PC board. Be sure of its alignment and avoid excess solder but be sure the ground leads are soldered up to the ceramic package. After all of the MMICs have been installed, (U1 -U6) use an Ohm meter to check for shorts on the input and output leads to ground. If you did a good job in prepping the PCB in step #2, you should have no problems. If you do find a short, try wicking some of the solder from the shorted lead with Solder Wick®. If still shorted, try lifting the problem lead and re-wicking. Be careful not to break the lead. A close inspection should reveal a short. Use the knife and re-move, then re solder and re-test again.

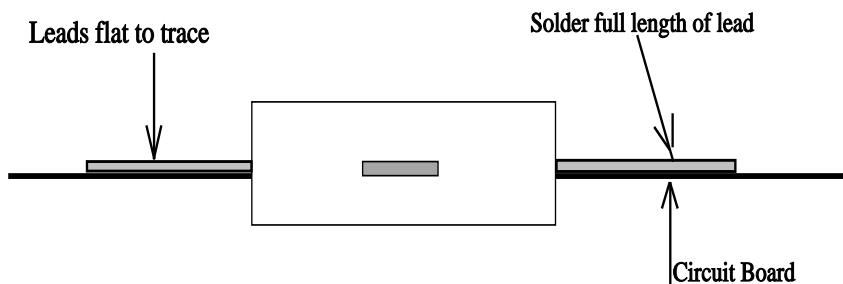

Figure 3. U1-U5 MMIC Installation (Also see addendum)

9. Install all capacitors from C1 - C25. The 0.1uF, 100 pF and most of the 6.8pF capacitors are connected from the DC circuitry to ground. Install and solder the groundside only. You may

want to re-heat the pallet again to ease this installation and improve the solder flow. Be sure that the component is flat to the circuit board before soldering as shown below. Do not solder the DC side of the capacitors. Place C11 in the LO test position, C11A.

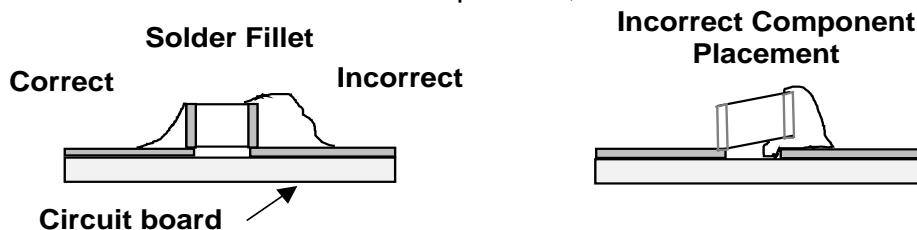
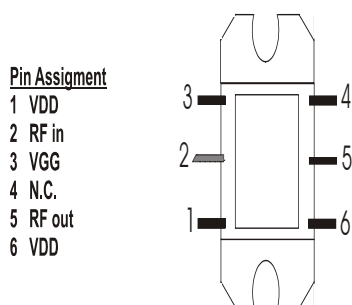

Figure 4. Proper SMD Assembly.

After all of the capacitors are installed, install resistors R1 – 13. You will not need any extra heat for installing the resistors. The resistors share the solder pads with the by-pass capacitors. Be sure that the resistors are flat to the surface and solder one side at a time. When soldering the resistor, solder the capacitor that shares the same pad with the resistor. After the resistors are finished, review all connections for missing solder or components. **Do not install D1 and D2!**

10. If you have the 5760-144 (3 watt version) begin to install all of the components listed in the 5760 LNA and power amplifier section components list. Note the polarity of capacitors C28, C31, C41, C42, C44 and C43 (the white line is positive). Install R14, R22, and IC2 from the filter side of the assembly. Lightly coat the base of IC1 with a small dab of thermal compound. Spread it thin to a transparent thickness. Install IC1 on the pallet with 3-48 X 3/16" screws so that the input lead, pin 2 (angle cut lead) is attached to the same pad as F6. See pictorial below. Check all pins for alignment and tighten the screws before soldering the leads. Next install Q1. The gate lead is indicated by the dot. Verify all leads of the IC's and Q1 are connected and not shorted with an ohm meter then install all other components in the LNA- PA section except the filter pins. Pins 1 and 6 of IC 1 are the Drain leads of the FET. They will measure a very low impedance to ground (1-2 ohms).



11. Install the bias wires as shown in figure 6. The figure shown is the full size pallet but the LP assembly only is indicated. All wires come in through the back of the pallet through the 1/8" clearance holes. They get soldered to the circuit board where indicated on the component placement diagram and some are labeled on the circuit board. They are labeled -5V, +VTX, +VRX, and +9. Using the #28 Teflon wire, cut, strip and tin the ends of a 2.75" length. Connect the two +9 by F1 and F2 together by inserting one end of the wire through the hole by F2 and solder it to that pad. Cut, strip, and tin three 6" pieces of wire. Insert the end of one 6" wire with the loose end of the 2.5" wire previously soldered through the +9 hole by F1. Solder both wires there. Now

connect a 6" wire in both the +VTX (by F4) and the +VRX (by F1). The LP version pallet is complete with wires.

If you have the 3 Watt version transverter, cut two 9" #28 for the +VRX and +9 connections near IC2. Cut a 1.25" and a 3.5" #28 wire. Install one end of each in the -5V connection points near IC2. Run the short one to the -5V by R22 and the long one to the -5V by R14. Now install a 8-32 feed thru in the pallet hole that is close to IC1. Attach a 1" #24 wire (largest gauge in kit) to the pin of the feed thru. Now install the 10 watt, 3 ohm resistor using two 3-48 x 1/4 screws on the filter side of the pallet as shown. Solder the 1" #24 wire to the one end and then connect a 9" #24 wire to the other end.

5760-144 Bottom Assembly Layout

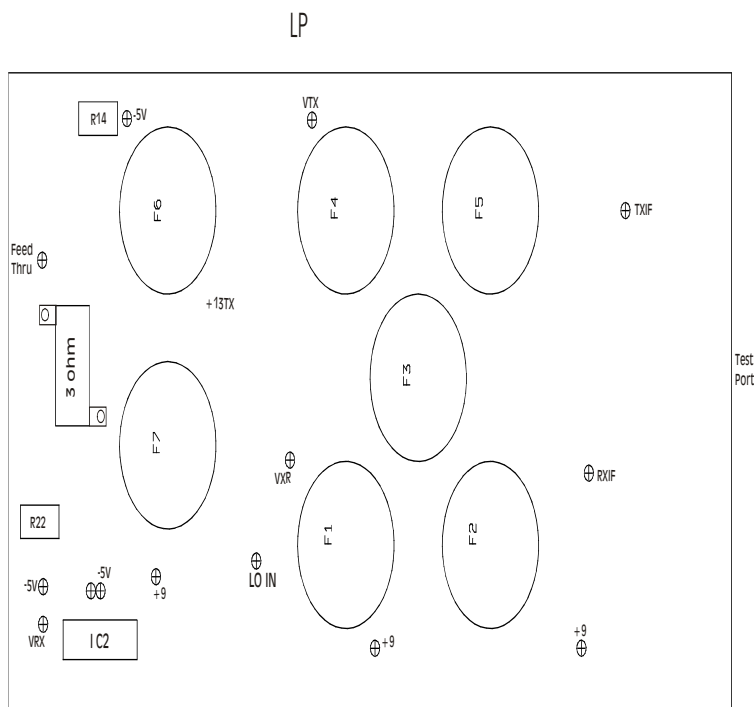

Figure 6. Filter Side of PCB Board

12. All of the coax connections need to be made next. Start by cutting three 8" pieces. The best way of making this coax assembly will result in something that looks like diagram "B". Start by removing approximately 3/4" of the outside jacket. Tin solder the entire exposed shield. Place the Rivet in position and solder in place. Try to keep the coax in the center of the rivet while the solder cools. Now with a #22 wire stripper, remove the shield that is below the rivet. The wire stripper should score the shield if it is tinned and you will be able to "Snap" off the shield. Then with a #28 wire stripper, remove the insulation off of the center conductor. Leave a small amount of insulation as shown in the diagram. Tightly wrap the exposed center conductor and lightly tin the end. Be sure not to let the solder expand the diameter of the center conductor.

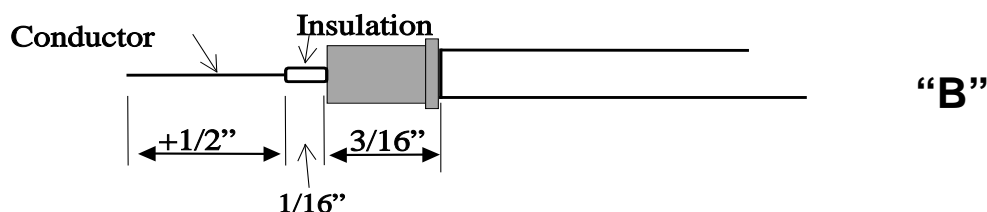

Figure 5. Prepped Coax details.

Once the coax is prepped; insert the center conductor through the hole in the pallet and then through the hole in the PCB (either RXIF, TXIF or LO IN). The reason in making the center conductor so long is so you have a guide for insertion. Pull the center conductor through and clamp into place with a 4-40 x 3/16" screw. Do the same for the other two coax cables. After all coax are installed, cut off the excess center conductor and solder it to the circuit. **Now install D1 and D2.** Be very careful with the lead alignment.

13. Refer to Figure 7 and install the rear panel to the PCB by first prepping the SMA connectors so that the Teflon will not interfere with the circuit board. Do not use the SMA that was installed on the LO test point. Use the rear panel as a guide and trim the excess Teflon from the SMA's with a sharp knife. Cut the pins to 0.100" extending from the Teflon. Attach the SMA connectors to the panel with the #3-48 x 3/16" screws. (4 total) Then attach the panel to the PCB with the 5, 3-48 x 3/8" screws. Note where the ground lug is mounted. Look for any gaps or bulges between the pallet and the panel. If needed, disassemble and re-cut the Teflon on the SMA's or trim the circuit board. This "perfect mating surface" is required for the RF grounding of the SMA connectors to the pallet. Be sure of a proper interface of connector, panel and pallet. Install the BNC connector or connectors and 3 DC feed-thru connectors in the end panel. If you are using a common IF you only need one BNC connector.

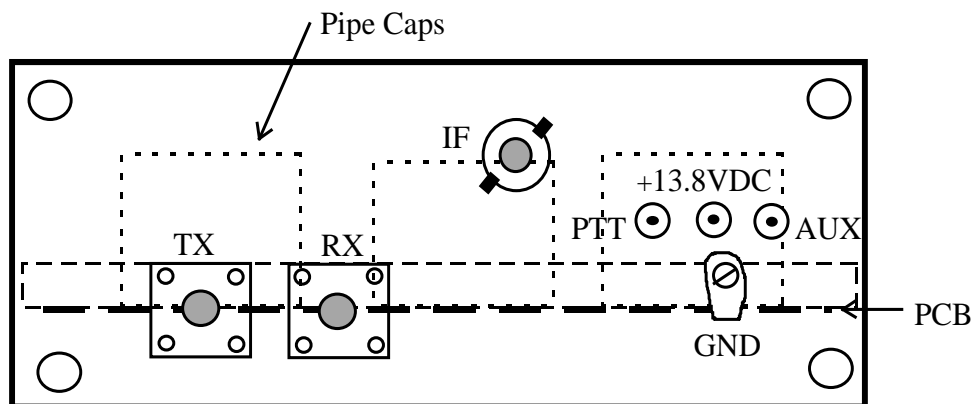

Figure 7.

14. Install all of the filter hardware. The screw heights should be pre-set for tuning. Install the 8-32 screws and lock nuts in all of the filters and screw them down by hand until the bottom of the head of the screw is about 1/4" from the lock nut. This is the best starting point for tuning. See

the diagram below. Also, note the length of the filter pins. This is the correct length but the pins are not installed until the testing procedure.

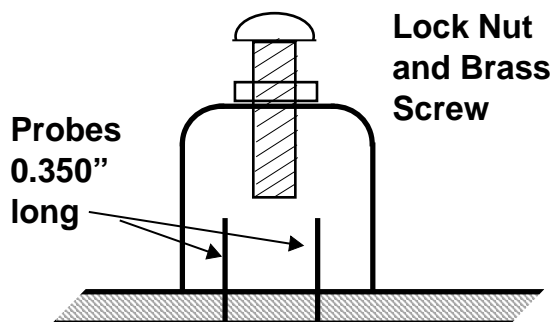

Figure 8

Pre-Test Re-inspect all solder connections. Touch up what is questionable. Then review the test procedure before proceeding. Using the assembled unit for a “Dry Run” may clarify some of the testing requirements that may have been in question when first read.

Different types of tune up procedures are possible with this transverter. The one described below assumes the minimal amount of test equipment available. If you have a spectrum analyzer with a good dynamic range, then tune up is even simpler. A good microwave power meter will also make the procedure go smoother. But if you only have a power detector as described in W1GHZ's QEX article, the job can still be accomplished. Read through the complete tune up procedure before starting and determine how you will best proceed. There are a few components that will need prepping and a determination of what power supply will be used to complete the testing. Whatever type of equipment is use for testing, proceed with the procedure below

DC Testing: of LP section

1. With an Ohm meter, check all resistors and wire connections for shorts or opens. Then check the RXIF and TXIF cables for shorts. If you completed the basic ohm meter testing of the MMIC leads in Assembly step #8 and #10, the transverter should be ready for DC and RF testing. You will need a regulated +9VDC supply voltage to complete the testing. If you do not have a power supply capable of this, you may use the regulated 9 volt output of the TC circuit board if you have the K or CK version. Be sure to attach a heat sink to the regulator and solder connections to the TC board to avoid clips leads.

2. The MMICs, U1 - U6, if working correctly, will draw current. This current drain will cause a voltage drop across its respected resistor network. With a +9 VDC applied to the network, the voltage drop should be approximately 5.3 volts. This means U1 - U5 should have +3.5 to +4.0 VDC on the output leads and +2.5 VDC on the input leads. The input lead voltage may vary up or down as much as 0.5 VDC or more.

Apply +9VDC to the +VTX, and +LO one at a time (ground is the pallet or circuit board) and check the voltages on the leads of the MMICs in those circuits. If large discrepancies occur, check the bias resistors for correct value. If a MMIC does not draw current, it is dead or the resistor network is open. If it drops voltage down to less than 1 VDC, the MMIC is shorted or the resistor network is open. Seek the problem out and repair. Use the generic layout below for test points.

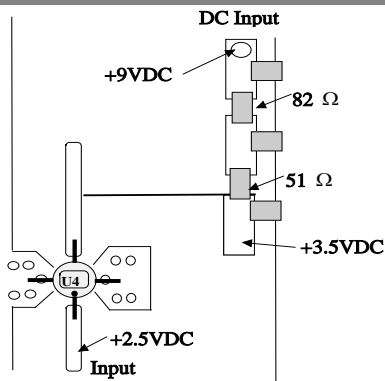

Figure 9. Resistor Network with Voltage Points

To test U6, (VRX), the MGA86576 output lead should measure between +6 and +7 VDC. If it is over 7.2 VDC, remove bias immediately and check the bias resistors for proper values. If the values are correct, R13 may need to be adjusted up in value. If it is less than +5.5 VDC, the MMIC may be oscillating which could be caused by the filter not being tuned yet. Place your finger on the input of the MMIC to verify if the voltage changes in a upward direction. If the voltage measured is less than +2VDC on the output lead, it may have a solder short under either lead. Check, and repair.

DC Testing of PA and LNA Section.

1. Test the output device IC1 by first applying voltage to the +9 lead near VR1. This should supply power to the DC to DC converter, IC2. IC2 will produce the negative voltage required for Q1 and IC1. Adjust R14 for -5.0 VDC on pin2 of IC1. Adjust R22 for -0.35 VDC at junction of C33 and Q1. **During this next test be sure that the +9 remains connected to IC2. If Q1 or IC1 lose the negative supply voltage, damage may occur!** Connect the VRX line to the +9VDC supply and measure the voltage at the R18 Q2 junction. It should be around +5 VDC but may be as high as +7VDC. Now measure the voltage at R15 between it and C36. Adjust R22 to obtain a measurement around 2.5 VDC. Remove the VRX voltage. To DC test IC1, you should have a 50 Ohm load on the TXRF connector. **With the +9 still connected to IC2,** Verify that there is -5VDC on pin 3 of IC1. If not, adjust R14 to obtain it. Then apply +13.8 VDC to the 9" wire that connects to the 3 Ohm power resistor and verify a voltage drop across the 3 Ohm resistor of 3-4 volts. **Remove the +13.8 VDC voltage first then remove the +9. If the +9 is removed first, the current will soar and you will damage IC1.** The DC check is now complete.

Tune-up:

This tune-up procedure will tune one filter at a time, adding additional sections of the circuit sequentially. Since the filters are separated by amplifier stages, interaction between them is minimal and re-peaking previous adjustments is unnecessary.

1. Attach the previously installed SMA connector to the LO test point. The MICRO LO board (after testing) is then connected to the 8" piece coax from the LO port of the transverter. Solder the coax (shield and center conductor) to the backside of the MICRO LO PCB.
2. If you are using a spectrum analyzer to tune the transverter, install all of the filter pins (14) as shown in figure 8. The pins that are supplied in the kit are the correct length (0.300"- 0.350" long) if you just cut off the tapered sharp points. Now insert and solder. Connect the spectrum



analyzer to the LO test point and apply 9VDC to the +9 on the transverter and to the MICRO LO. Adjust F1 and F2 for maximum signal. When complete, remove voltages, and move C11A to the C11 operating position connecting the mixers to the LO. Then remove the SMA test connector. Proceed to step #6.

3. If you are using a power detection instrument, In order to tune the LO chain, you must only tune one filter at a time. To do so, install the pins in F1 only. F2 must now be by-passed. Using a wire soldered across the filter will DC short the input of U3 to the output of U2. Find the supplied # 24 enamel wire and cut 2 pieces approx. 1/2" to 3/4" long. Tin one end on each. Place one wire across the gap in F2 and solder the tinned end to the circuit board where the filter pin is normally attached. Be sure it is flat on the board. Then attach the other wire to the opposite side of the filter so that the wires are across the filter forming a "Gimmick capacitor". The wire should be laying parallel to each other in the filter gap. This allows the RF to pass but isolates the DC voltage. **DO NOT USE A LEADED CAPACITOR IN PLACE OF THE WIRE!**

4. Be sure that the enamel wires are not DC shorted and are laying flat on the circuit board. Connect a power meter or other measuring device to the SMA connector on the LO test point. Apply the same 9 VDC power to both the MICRO LO board and +9 that you used during the DC test on the transverter circuit board. Tune filter F1 for maximum power by turning the screw down in to the filter. Peak it and secure the lock nut. F1 is done. If you have a accurate measuring device, there should be approx. 10 mW (+10 dBm +/- 2 dB). If you are not sure of power level, then note the reference level achieved. With this setup, you cannot tune the wrong harmonic. (If the LO input is 1123.2 MHz.)

5. Proceed to filter F2. Remove the "Gimmick Capacitor" wires, insert and solder the probe pins, and adjust the tuning screw to the same way as F1. Apply power again, peak the tuning screw of F2, and be sure to lock the nut. If you are able to measure power, the output at the test point should measure >+8 dBm for best all around performance. If you have a reference level the power out should be around 2 dB less than the F1 filter only. If the power is slightly low, (levels down to +3 dBm are usable) you can try to re-peak both filters again. Anything higher than +10 dBm will start to degrade the system noise figure in the receive side and increase spurious in the TX side. Now move C11A to the C11 operating position connecting the mixers to the LO. Then remove the SMA test connector.

6. Now that the local oscillator is complete, you should begin to assemble the TC in the enclosure Using the TC installation instructions and Figure 10 as a location guide. Install all connections except the 3 Feed through connectors to the PTT, +13.8, and AUX. Be sure to make all wire and coax connections to the TC on the topside. If you have the 3 watt version, make all connections from PA and LNA section in the transverter to their matching connections on the TC. Do not shorten any of the wires or coax for now. Connect the DC input of the MICRO LO to the +9 connection by the regulator on the TC board. Install one or both BNC connectors in the connector panel and connect them to the TC with 12" coax as you wish the transverter to be configured. Connect a 9" #24 wire to the +13.8 on the TC. This is the DC input for the transverter. Be sure of the drive level that the TC is configured for and review the Operation instructions of the TC before going on to Step #7.

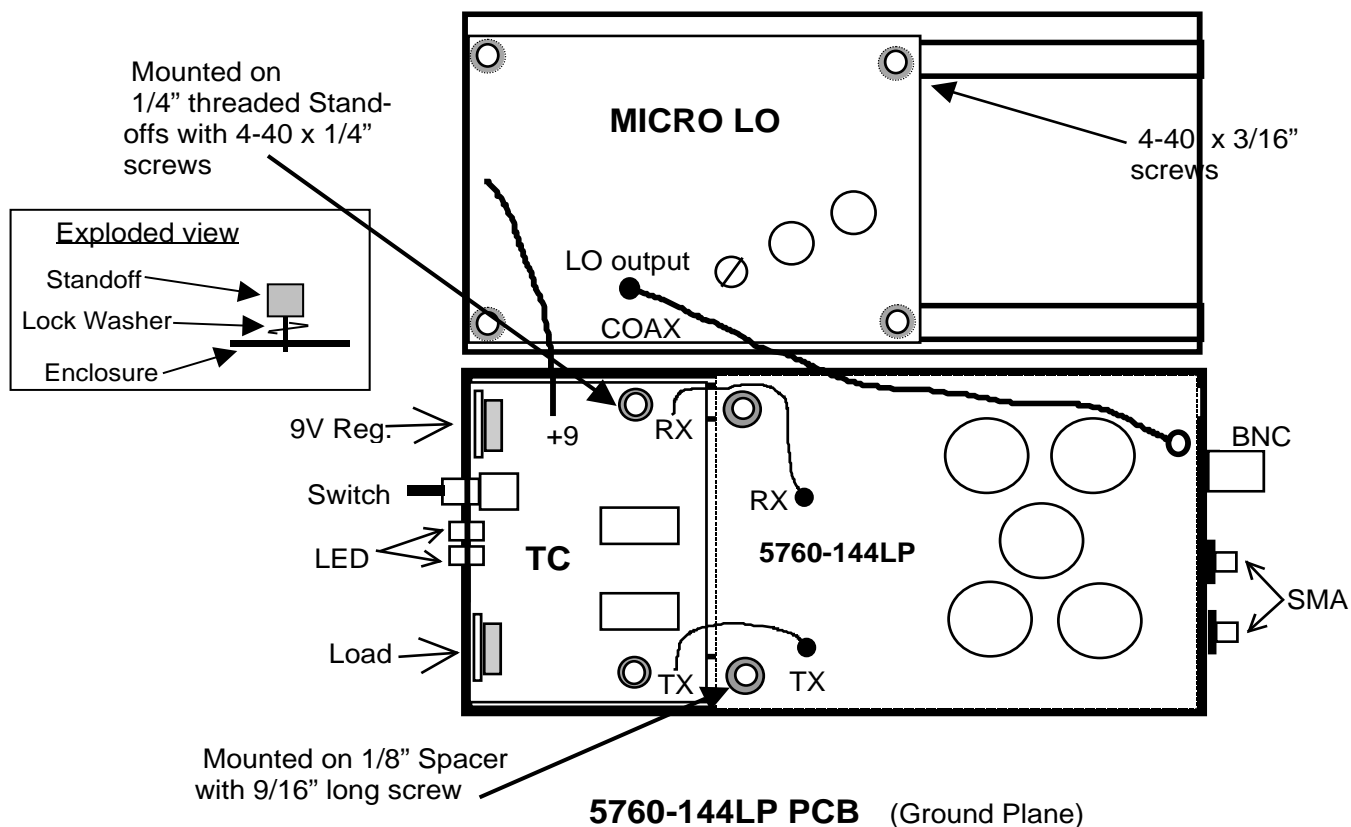
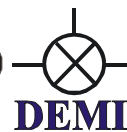

Figure 10.

7. Connect a 13.8VDC supply to the DC input of the TC. Turn the power switch on. The LED should light. Verify the voltages to the individual sections of the transverter. *If you have the 3 watt version, check the -5VDC points first.* Then check to see if Q1 is drawing the same current as in the DC test. Verify all other +9 and VRX connections are correct. Then you may cycle the PTT to verify the VTX voltages. If you have the 3 watt version, install a 50 ohm load to the TXRF port first. Check the voltage drop across the 3 ohm power resistor. It should remain at 3-4 volts. If all DC voltages check, proceed to next step.

8. Unless you are testing with a spectrum analyzer (Just install probes and Tune!). F4 is bypassed with a "Gimmick Capacitor" If you have the 3 watt version install a gimmick capacitor across F6 also. Install the probes in F5 and connect the 144 MHz. IF drive source to the transverter. If you have a low level source, you may connect it directly to the TXIF pad on the TC to drive the TX mixer at a 1 mW level. If using the TC assembly with a higher power transceiver adjust the level correctly. **WARNING! More than 30 mW of drive may burn out the diode pair.** Move the 5760 output power indicator to the TX out connector, then key the PTT. Since filter F5 should be tuned 144 MHz higher than F1 or F2, the peak should be about a half-turn less than the screws in the LO filters. Peak and be sure to snug the lock nut. Proceeding to F4, remove the bypass wires, and insert and solder the probe pins. Set the tuning screw to the same depth as F5. Apply power again, peak the tuning screw. The transmitter is now complete if it is the LP version, and should have a typical output power of >+10 dBm. If you have the 3 watt version, insert the pins in F6 and adjust for maximum power output.



9. The final step is to tune the receiver section. Connect the RXIF to a 144 MHz. receiver and the RXRF to a weak signal source on 5760 MHz. Install the probes in F3 and Peak it. If you have the 3 watt version, install the gimmicks on F7 then peak F3, remove the gimmicks, insert the probes in F7 and adjust F7 for best signal. Optimizing R14 is possible but you may only see a minimal effect unless you have a noise figure meter. Otherwise, you are done with the tune-up but should be checked again after final assembly!

Final Complete Assembly:

If you have the complete kit, assemble the transverter using the supplied hardware per Figure 10. The MICRO LO is mounted to the opposite half of the enclosure as the transverter. Please verify the orientation of the MICRO LO before attaching it to enclosure. Remove the 4-40 nuts from the 9/16" screws and with the 1/8" spacer and install the transverter in the enclosure. Only start the 4-40 screws. Then start the two panel screws and when the alignment is correct, tighten all four. You may now shorten all wires and coax to clean up the "Rats Nest". When you become satisfied with the length of the wires, you may want to bundle all of the control wires and coaxes together to make a neat appearance. It is not necessary, but it will contain the wires to make closing the enclosure easier. Keep the MICRO LO wires and coax separate from the rest of the transverter wires.

Final Testing and Completion:

Once the configuration of your transverter and IF rig is established, you may retest and or retune the RF stages of the transverter. Be sure to start with maximum attenuation in the TX path before transmitting. Adjust the levels of TX and RX gain as required. Do a final check on the TX and RX IF levels and if you are satisfied, close the enclosure and bolt it with the four remaining flat-head screws. Be sure not to pinch the LO coax and DC wire between a filter screw and the MICRO-LO PCB. Then re-test the transverter after closing.

Performance:

The LP version has about 10 mW's of transmitter output and about 3.5 dB receiver noise figure. These specs make an excellent rover rig as is but if you can measure noise figure, R13 may be optimized for best noise figure and gain but my only get you 2 or 3 tenths of a dB. Be careful not to exceed 7 volts to the output lead of the MGA86576. F2 (the LO filter) may also be optimized for best noise figure. This is because the LO power may be excessive, and imbalances in the RX mixer diode may occur. F2 can be adjusted for a little more insertion loss (if you have a "hot LO" but this will affect TX output power so a re-test may be required to verify if you have made any improvements at all. You may adjust F2 for the best compromise if required but only if you have the test equipment!!!!

If your plans are to install external equipment to improve both the Transmit and receive, test everything as an assembly. Use filter and isolators for prevention of un-wanted results. The transmitter output is double filtered producing a relatively clean output. The transmitter has some LO leakage, about 40 dB down from peak carrier output, and the image signal is about 45 dB down. The LO leakage is about 45 dB down when the transmit section is not powered; so more shielding would be required for significant improvement if required. All other spurious outputs are >60 dB down except the second harmonic, which is 40 dB down. On the receive side, a single filter provides adequate image rejection to maintain good noise figure. This performance is probably similar to lower-frequency "no-tune" transverters and makes an excellent foundation for a high-performance system.



If you have assembled the 3 watt version, you will find the extra filtering, the addition of the LNA, and the +3 watt power amplifier, makes a complete state of the art 5760 MHz. station that is ready for any DX that is possible. And it's all in one enclosure!

Conclusion:

This completes the assembly and testing of the 5760-144. You now have enough knowledge of how this assembly works that implementing it into a existing system should not be a technical problem. Remember that the unit is designed to operate from a +13.8VDC source but any voltage between 11 and 16.5 VDC will work making it perfect for portable operation. You may wish to and should test this before going portable.

If the transverter is to be used in a high performance terrestrial or EME set up, a mast mount LNA that has better noise performance may be desired. If so, additional filtering and isolation may be required and/or the use of the RX IF gain stage in the TC may need to be omitted. If a higher power amplifier is added, consider an additional filter and/or isolator. Also consider some attenuation if using a high gain TWT amplifier for +5dBm output of the transverter may be too much driving power.

As for portable operation, the transverter can be interfaced with our AOS-144 RF sensed IF switch attenuator that may be used with transceivers up to 25 watts output. Higher output power transceivers are not recommended unless modified. Addition of external power amplifiers and LNA's can be accomplished with the AUX output of the transverter or by implementing a sequencing scheme. Remote location mounting is possible with this unit in its stock form. It would just need to be installed in a weatherproof enclosure.

We hope you had fun with this kit and that you enjoy many hours of operation with your completed 5760-144. Please take time to read the papers published by W1GHZ (N1BWT) for other operation tips and suggestions including antenna designs and to check out some of the notes listed at the end of this document. We hope your experience with this kit was and enjoyable one.

Good luck with the DX and have fun!



5760-144 Assembly Addendum

There is a copper foil attached to the bottom side of the 5760-144 circuit board in the power amplifier MMIC position. This has been added to improve the grounding and stability of the amplifier. Just attach the board as shown in the assembly manual before the pipe cap filters are installed. Do not apply heat sink compound between the copper and the aluminum pallet. Just place a dab of compound on the bottom side of the MMIC and spread it evenly to a transparent state before the MMIC is installed. The compression of the MMIC to the pallet will "Smooth" the copper and then it will provide adequate grounding and heat transfer.

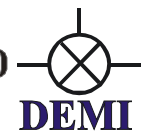

5760 -144LP Transverter Board Component List

All components are Surface Mount

C1 100 pF	C11 6.8pF (0603)	C21 100 pF	R5 82 Ω	U2 ERA-1
C2 0.1 μF	C12 6.8pF (0603)	C22 0.1 μF	R6 51 Ω	U3 ERA-1
C3 100 pF	C13 100 pF	C23 0.1 μF	R7 51 Ω	U4 ERA-2
C4 0.1 μF	C14 0.1 μF	C24 6.8pF (0603)	R8 51 Ω	U5 ERA-2
C5 0.1 μF	C15 100 pF	D1 MA4E2054	R9 82 Ω	U5-LP ERA-4
C6 100 pF	C16 0.1 μF	D2 MA4E2054	R10 130 Ω	U6 MGA86576
C7 6.8pF (0603)	C17 6.8pF (0603)	R1 51 Ω	R11 130 Ω (LP opt)	2" #24 enamel
C8 0.1 μF	C18 6.8pF (0603)	R2 82 Ω	R12 51 Ω	
C9 100 pF	C19 6.8pF (0603)	R3 82 Ω	R13 100 Ω	
C10 6.8pF (0603)	C20 0.1 μF	R4 51 Ω	U1 ERA-2	

5760-144 LNA and Power Amplifier Section

C26 100	C34 2.7 pF 50mil ATC	C42 10.0 μF	R14 200 Ω pot	R22 1K Ω pot
C27 100	C35 2.7 pF 50mil ATC	C43 10.0 μF	R15 10 Ω(0805)	VR1 78M05
C28 1.0 μF	C36 6.8pF (0603)	C44 10.0 μF	R16 51 Ω	3 Ω 10W
C29 1.0 μF	C37 0.1 μF	D3 MMBD914	R17 51 Ω	4-40 Feed Thru
C30 100	C38 0.1 μF	IC1 FMM5056VF	R18 100 Ω	
C31 1.0 μF	C39 0.1 μF	IC2 NMA0505S	R19 5.1K Ω	
C32 2.7 pF 50mil ATC	C40 0.1 μF	Q1 ATF36077	R20 5.1K Ω	
C33 2.7 pF 50mil ATC	C41 10.0 μF	Q2 MMBT3904	R21 5.1K Ω	

FILTER COMPONENTS

5760-144LP	5 - 3/4" Pipe caps	5- 8-32 plated nuts	12- brass pins	5- 8-32x 5/8" Brass screws
5760-144	7 - 3/4" Pipe caps	7- 8-32 plated nuts	16- brass pins	7 - 8-32x 5/8" Brass screws

5760-144 Hardware Components

3- 1/8" x 3/16" Rivets	7- 3-48 x 3/8" screws	2-1/4" threaded standoff	4' #28 Teflon Wire
23- 4-40 x 3/16" screws	2 - #4 lock washers	50 ohm load	1 - Rt. Angle switch
1- 4-40 x 3/8" screws	2- 1/8" Spacers	2- BNC connector	2- Machined End Plates
2- 4-40 x 9/16" Screws	1 - # 4 Ground Lug	3- SMA connector	8- Flat head screws
3- 4-40 x 1/4" screws	2- 4-40 nuts	4' #24 Teflon wire	1- Machined Enclosure
6- 3-48 x 3/16" screws	3- 8-32 feed thru	36"- RG-188 coax	Labels
2- 3-48 x 1/4" screws			

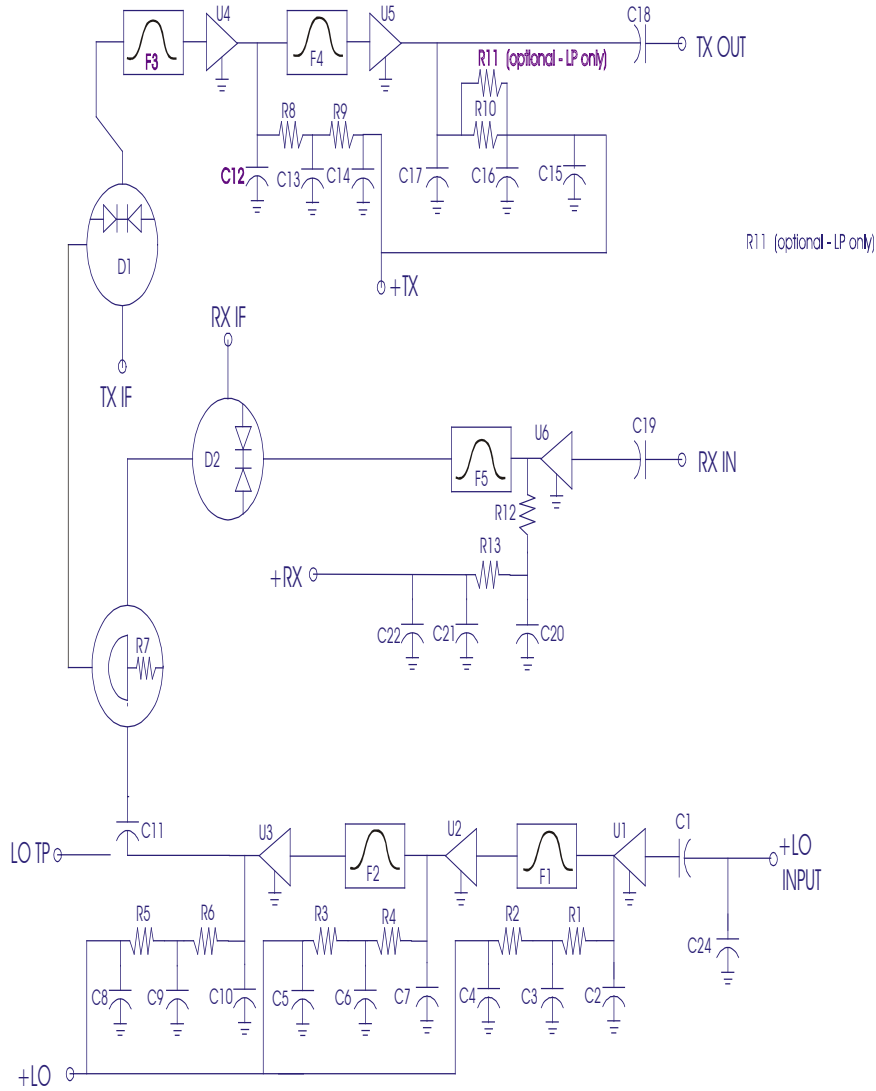

5760-144LP TRANSVERTER SCHEMATIC

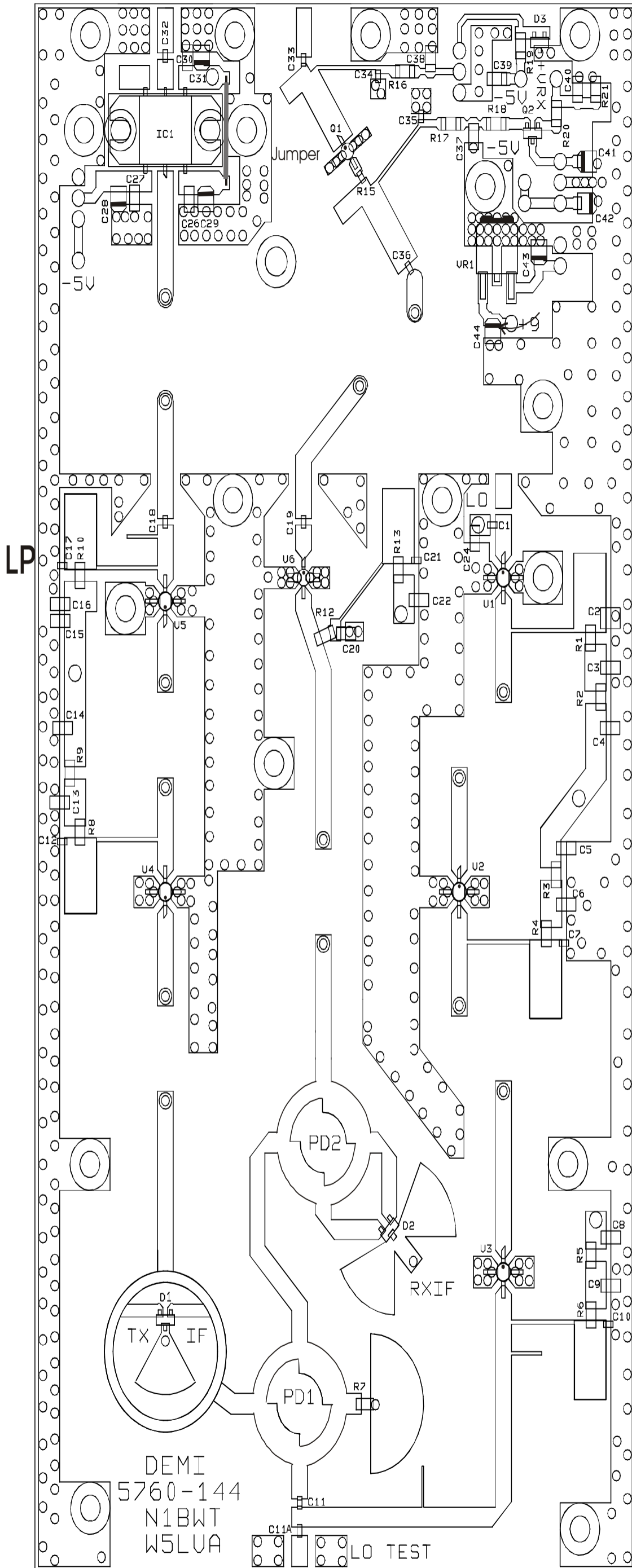

5760MHz Transverter Top Assembly Layout

NOTE - R14, R22, I C2 AND F1-7 ARE LOCATED ON THE BOTTOM SIDE OF THE PC BOARD.