

**DEM Part Number 5760-144**\_\_\_\_\_

**5**\_\_\_\_\_ **MHz. Transverter,** \_\_\_\_\_ **MHz IF, SN**\_\_\_\_\_

Power Out:	>2W adjustable	LP version: > 10 mW
Noise Figure and Gain:	<1.5dB @ 17dB G	<3.5dB
DC Power Requirement:	10 - 15.5 VDC @ 2.5 Amp	<0.6 Amp
IF Option:	Common	Split
IF Drive Level Requirement:	1-250 mW 250mW-3W 3-10W	Other_____
Keying Option:	PTT - to ground	TTL - Positive Voltage
Aux. Connection Output Option:	TX RX High Low RVD	
Antenna Option:	Common	Separate TX & RX
10 MHz source	Internal	External

**Operational Overview**

The DEM 5760-144 is a 5 cm to 144 MHz transmit and receive converter. It has a linear output power of >2 watts ( > 10mW for LP version) and may be achieved with as little as 10mW or a maximum of 10 W of IF drive with the correct IF configuration. The receive section is a design using a PHEMT LNA (GaAs MMIC in the LP). The base local oscillator frequency is provided by our A32 synthesizer. It is either configured with an external or internal 10 MHz clock. The DEM 5760-144 has a built in transmit / receive relay driver to provide voltages required by common SMA relays and provisions for external switching so adding a high power amplifier or preamplifier to your 5cm system is easy. TXIF level options have been built into the transverter. The IF levels are adjustable on both transmit and receive and have a dynamic range of approx. 25dB. This is useful for adjusting your maximum output power and setting the "S" meter level on your IF receiver. The IF connections are via BNC connectors. Options have been provided for a key line input PTT-H (+1 to 15 VDC) or PTT-L (a closure to ground) and auxiliary contacts on either transmit or receive with a common line for many applications. The control, power, and auxiliary connections are via DC feed thru connectors and the 5cm connectors are SMA. The 5760-144 is housed in our standard 4.125" x 1.875" x 9.75" extruded aluminum enclosure that matches the all of our other microwave transverters.

**Connect your transceiver to the transverter:**

Interfacing the transverter to the transceiver is easy. First review the assembled configuration above. If the transverter was configured for direct connection to your transceiver (10 watts or less), follow the steps listed next.

1. Open the top lid of the transverter by removing 4 screws. Be careful because the LO is mounted to the lid.
2. Connect all IF cables. The transverter may have a common IF port or two separate ports TXIF and RXIF. Use good quality coax cable to connect the ports between your transceiver and the IF connectors on the transverter.

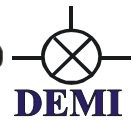

3. Connect the Push to Talk line out of your transceiver to the transverter. It is labeled PTT-H or PTT-L on the transverter and uses a solder type DC feed through connector. The correct keying type can be configured for your transceiver at time of order or you may select it in the transverter now by moving the PTT jumper.
4. If the WTR option was not ordered, you will have separate TX and RX ports. You may connect your own transfer relay at this time or continue interfacing without it. Connect your 5cm antenna system or a dummy load with a power meter to the appropriate transverter ports. Always terminate the receive port with a 50 ohm load.
5. Connect the external 10 MHz clock if you did not order the internal clock ,
6. Connect the DC power to the transverter. It uses a DC feed through type connector. 13.8 volts is optimum but the transverter will operate normally from 11 to 15 volts.
7. Preset the TXIF and RXIF gain controls in the transverter. Turn both controls fully counter-clockwise. This is maximum attenuation on Transmit and minimum attenuation on Receive.
8. Power your transceiver "ON" and leave it in the Receive mode on 144.100 MHz. This should be 5760.100 unless you ordered a different frequency scheme. The Green LED and the Blue "Lock" LED should be lit. You can test the external 10 MHz clock by disconnecting the clock. This should either produce a blinking blue LED or totally off.
9. Adjust the RXIF gain control until a slight noise increase is heard in the transceiver or just a slight movement in the "S" meter is detected. Power the transverter on and off to verify the change of noise in the transceiver. You may also remove the 50 ohm load to determine receiver performance. Find a signal on the band or use a signal generator to determine correct frequency, or minimum signal level desired. If you are planning on installing an external LNA you may adjust the IF level after installation.
10. It is recommended to test the transverter in the CW mode because most transceivers have carrier level controls in this mode only. Do not use full or semi break-in if possible. Do not use FM , SSB or AM because it may not be possible to obtain maximum output power with your transceiver in these modes. Set the carrier/output power control on your transceiver to minimum or "0" output power. Place the transceiver into transmit. If the PTT circuit is connected correctly, the transmit LED on the transverter will switch on. While observing a power meter on the 5cm system, slowly increase the carrier control (with key down) or increase the power output control to maximum on the transceiver. If the transverter is configured correctly for your transceiver, minimal power may be detected on the power meter. Slowly adjust the TXIF control in the transverter in a clockwise direction while observing the power meter. Set it to obtain a saturated power reading and then just back off a little to avoid total saturation. If a power meter is not available this will be difficult. You may use a current meter on the DC power line to determine if the transverter is transmitting. A maximum of 2.5 amps should be obtainable and it should not vary as the TXIF control is adjusted. When maximum power is achieved the current will suddenly decrease. This is saturation. Back off the TXIF drive to limit the amount of saturation. Switch the transceiver to USB and make a transmission. The power output and current drain should correlate to your speech pattern.
11. You may re-adjust both RXIF and TXIF again if desired. The local oscillator frequency should not need to be adjusted but you may if you wish. Do not adjust any of the filters unless you have access to a spectrum analyzer at minimum. It is also not recommended to adjust the bias pots of the LNA and power amplifier. They have been optimized.
12. Put the top on the enclosure and install the screws. Your transverter system is ready to use. Connect as you wish to use it in your 5cm system and have fun!

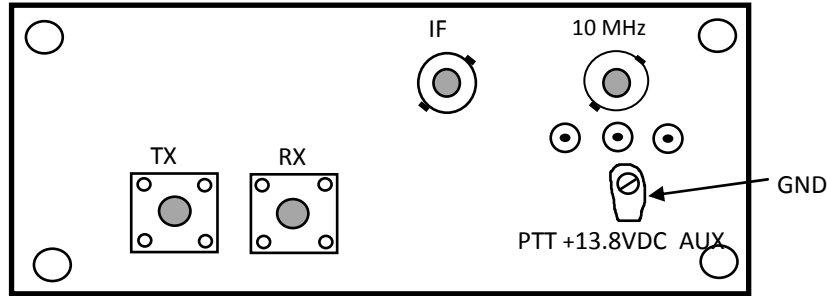

## DEM 5760 - 144 User Options:

### Auxiliary Switching contacts:

The auxiliary contacts on the TC board (see the TC document) are labeled C (common) NO (normally open) and NC (normally closed). The C connection can be wired to ground or +13.8 VDC. This will then be connected or dis-connected depending on if the transverter is in transmit or receive. The contacts are marked for the receive mode. The NO or NC can be wired to the AUX connector on the enclosure.

### PTT options:

Both PTT-H and PTT-L can be changed on the top side of the TC board. The connections are located in the center of the board near the connector panel. Change the jumper as required from the PTT connection to either "L" (Ground to transmit) or "H" (Apply positive voltage to transmit)

### IF options:

All possible IF configurations are shown in the TC document and in the supplied schematic. Follow the schematic and component list for changing the desired drive level ranges if you require a different configuration or drive level. Splitting the IF to separate TX and RX is also explained. Other combinations and drive levels may work but do not exceed 10 Watts input. The minimum TX drive level for without damaging the TX mixer diode is 20 mW. Do not exceed this level and try to limit the drive to 10 mW for a safety margin.

### Frequency Options:

For other frequency options or possibilities of dual frequency operation, see the attached A32 synthesizer document.

### 5760 -144LP Transverter Board Component List All components are Surface Mount

C1	100 pF	C11	10 pF	C20	10 pF	R3	82 Ω	R12	51 Ω
C2	10 pF	C12	10 pF	C21	100 pF	R4	51 Ω	R13	100 Ω
C3	100 pF	C13	100 pF	C22	0.1 μF	R5	82 Ω	R14	51 Ω
C4	0.1 μF	C11	10 pF	C23	0.1 μF	R6	51 Ω	U1	ERA-2
C5	0.1 μF	C14	0.1 μF	C24	5 pF	R7	51 Ω	U2	ERA-1
C6	100 pF	C15	1000 pF	D1	MA4E2054	R8	51 Ω	U3	ERA-1
C7	10 pF	C16	0.1 μF	D2	MA4E2054	R9	82 Ω	U4	ERA-2
C8	0.1 μF	C17	10 pF	R1	51 Ω	R10	130 Ω	U5	ERA-4
C9	100 pF	C18	10 pF	R2	82 Ω	R11	130 Ω	U6	MGA86576
C10	10 pF	C19	8.2 pF ATC						

**5760-144 LNA and Power Amplifier Section**

C2a 100 pF	C27 100 pF	C34 0.1 μF	C42 10.0 μF	R20 51 Ω
C3a 1.5 μF	C28 1.5 μF	C35 10.0 μF	R5a 200 Ω	IC2 NMA0505S
C4a 10.0 μF	C29 2.4 pF ATC	C36 2.4 pF ATC	R16 100 Ω	IC3 7660
C11a 2.4 pF ATC	C31 1.5 μF	C37 0.1 μF	R17 1K Ω	IC5 ATF36077
C12a 10.0 μF	C32 0.1 μF	C38 2.4 pF ATC	R18 51 Ω	IC6 TMD5872-2
C14a 2.4 pF ATC	C33 0.1 μF	C39 2.4 pF ATC	R19 5.1K Ω	CR3 MMBD914

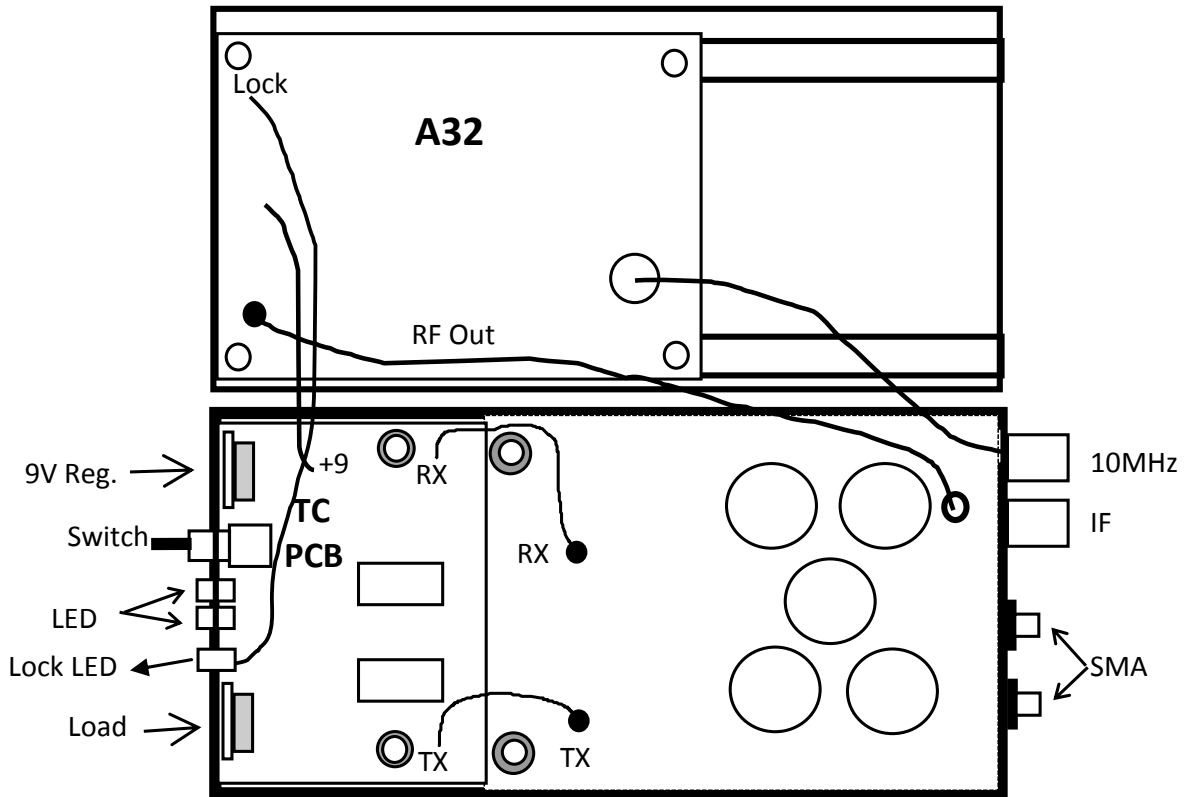

**5760 -144 LP Shown For Clarity**

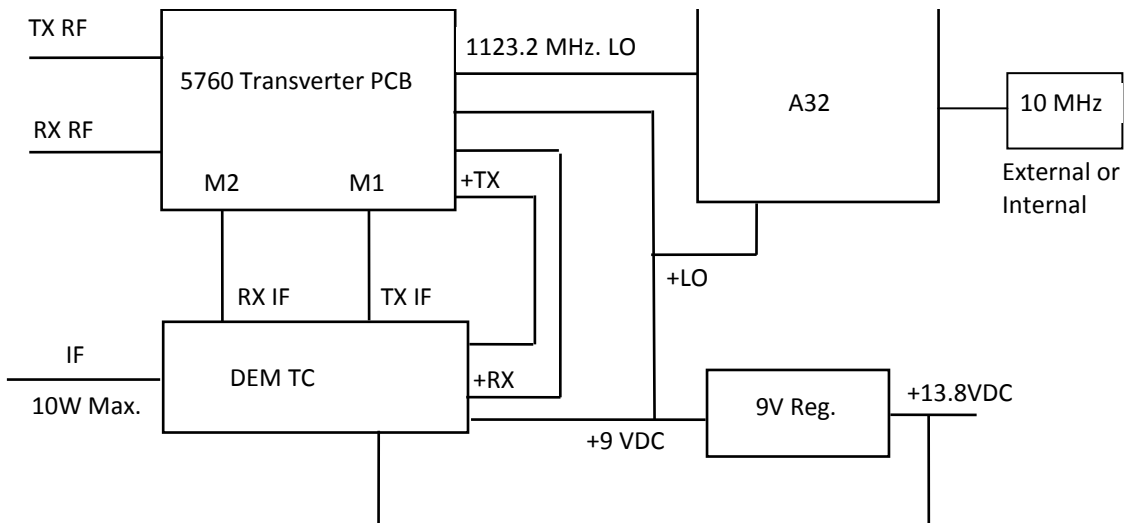

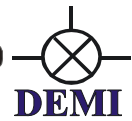
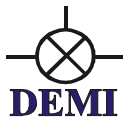

### A32 with Internal 10 MHz. Clock

The performance of the A32 synthesizer depends on the accuracy of the 10 MHz clock or standard it is connected to. For the best possible performance, we recommend using a GPS derived source. This not only guarantees the best possible performance but will ensure that you are on the same frequency as others using a GPS derived system. The next best option is an external 10 MHz. source that is temperature stable separate from the transverter it is being used with. The transverter temperature will vary depending on the ambient temperature and the amount of power dissipated as heat in the transverter. Hence, the low power transverters will be more temperature stable than the high power versions. The last option is to utilize an "on board" 10 MHz clock installed on the A32 synthesizer. This document will address the use and performance of what DEMI will install if a internal 10 MHz clock is desired.

The latest production A32 units have been designed to accommodate a surface mount TCXO produced by FOX, model 801BE. It was chosen for its performance over other designs. This model does have temperature compensation but it will not out perform an external source. The 801BE does have an internal trimmer control but we found it difficult to adjust so have installed an "on board" frequency trimmer. This trimmer is adjusted at room temperature (25-28 degrees C) for the correct frequency depending on the model of transverter and operating frequency chosen. This trimmer can be re-adjusted at anytime to compensate for your type of operation or oscillator aging.

The data provided below will demonstrate what to expect as the internal air temperature of the transverter changes. The data is a compilation of worst-case frequency change of different units tested in the lab at the specified temperature ranges. We believe this is a good representation of what someone could expect when using an A32 with an internal FOX 801 10 MHz clock. Because of the nature of the 10 MHz clock (being crystal derived), the frequency change over temperature depends on the characteristics of the crystal used in the circuit. This is why we specify it as "Change in frequency or Delta" and not actual frequency change in a positive or negative direction. The delta can be in either positive or negative direction from "0" offset or "0" could be the center of the range. Just understand that at any temperature range, the data is the maximum frequency change that was observed.

Next item to understand is that data is a measurement of the A32 frequency change. (The base LO Multiplier frequency) This means that if you have a 10 GHz transverter, the base A32 frequency of 1136 MHz, is multiplied 9 times. So, the delta specified needs to be multiplied by 9. For 5760 by 5, 3456 by 3 and 2304 by 2.

Last item is to not underestimate the operating temperature of the transverter. A high power 5 or 10 GHz. transverter if left unattended in the sun in the transmit mode can exceed an internal temperature of 60 degrees C! In a laboratory environment, 50-55 degrees C can be achieved with a 1/2 hour of continuous transmit time. Now, the data.

Operating Temperature	Delta Frequency Change in Hz.
-10 to +50 degrees C	375
+20 to +40 degrees C	200
+30 to +55 degrees C	110



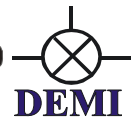
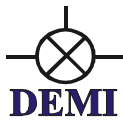

## **DEM TC**

### **DEM TRANSVERTER CONTROL**

The DEM Transverter Control (DEM TC) is the circuit board that controls all transverter functions in the DEMI 2.3 GHz. -10 GHz. transverters. It was designed with many options and depending on the configuration you have ordered (see configuration page of main transverter document), the options may or may not be enabled in your transverter. This document will cover all of the features available for understanding and make it possible to change the configuration at any time to suit your requirements.

**Circuit Description:** (All functions mentioned may or may not be enabled in your transverter)

The DEM TC circuit board is mounted in the front of the transverter. It includes the DC power switch and both the "Power On" and the "Transmit On" LED's. The TC contains a 1.5 amp, 9 Volt regulator that supplies the transverter with all of the regulated DC voltage it requires and allows some head room for other external circuits. The TC controls all of the IF switching functions utilizing a high isolation RF relay that is rated through 1 GHz. It allows the use of any frequency of IF up to 1300 MHz. On transmit it will allow the use of up to a maximum of 10 watts of drive depending on configuration. The TC also incorporates adjustable attenuators for both transmit and receive and has a provision for adding additional receive IF gain. The TC allows either a PTT High or Low for keying the transmit and receive circuits. Another feature included on the TC circuit board is a 24 Volt relay driver designed to operate most SMA relays used for Transmit and Receive switching of the RF frequencies. This circuit may not work with certain types of relays but will operate with any SMA relay supplied by DEMI. Other options include different auxiliary DC switching schemes, keying the transverter through the IF coax, and supplying PTT keying signals to external equipment. Connection and use of each circuit is explained below. Refer to schematic and component list for all component designations.

### **RXIF Gain and Adjustment:**

The installation of the receive IF gain stage is the most asked about device in the transverter. If the transverter is to be installed at the antenna with a long run of coax for the IF line, you may wish to install IC1. Understand that installing this gain stage will not improve the system noise figure and in most cases it will slightly degrade it. If you wish to improve the system noise figure, you should add a LNA at the RF frequency. Then depending on the gain of the additional RF LNA, you may not need the RXIF gain stage even if the transverter mast mounted. If you wish to install IC1, refer to the component placement to determine where it is installed along with its bias resistor R9. Any low frequency MMIC may be used but select it for the correct amount of gain required. Also consider the noise figure unless you have a RF LNA in the system. Select the value of R9 for the MMIC to be used for 13.8VDC operation. To bypass the gain stage, install a leaded 120pF capacitor in place of IC1. Keep the leads short.

The RXIF gain can be adjusted with R7. There should be approximately 20 dB of range. With your system completely connected, R7 may be adjusted to an acceptable level determined by your ear. For best results, keep the gain to a minimum. Only a slight noise increase should be noticed by cycling the power switch of the transverter. If your "S" meter of your IF radio is at half scale, you have lost half of the dynamic range of your system. For the same reasoning, adding the gain stage and then adjusting the RXIF to maximum will degrade the dynamic range further.

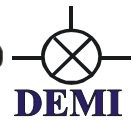

### **TXIF Drive Level and Adjustment.**

The TXIF drive level adjustment (R2) has approximately 20 dB of range. Depending on the configuration ordered, this adjustment range may not be acceptable. If so the fixed attenuator may need to be installed, removed, or adjusted. If you wish to use less than 50 milliwatts of IF drive power, install a short jumper wire in the R4 position and remove the large 50 ohm termination that may be installed on the front panel. If you wish to use up to 2 watts, install R4 as shown with the large 50 ohm termination. If you plan to use 1 - 10 watts of IF drive, install a 1pF capacitor in the R4 position with the 50 ohm termination. If you need to experiment with other drive levels, any combination of variable capacitor or resistor may be used in the R4 position. You may also adjust the values of R1 and R3 as needed. Input power to the TXIF adjustment is dependent on the attenuation installed on the C3 side of the K1 relay. The 50 ohm load resistor is designed to handle 35 watts with proper heat sinking. When mounted to the front panel of the transverter, it will not tolerate more than 10-12 watts reliably for a long period of time. You may experiment with external heat sinking if you desire. External attenuation may also be used in the transceive path. Remember that the added attenuation is also on the receive signal but may be overcome by the additional gain of the RXIF gain stage. The level then may be adjusted with the RXIF adjustment.

### **Split Transmit and Receive or Common IF Configuration:**

If you wish to use your transverter with separate TX and RX ports, first remove C3 and C5. Then attach coax from the IF connectors to the corresponding TXIF and RXIF connections at the C3 and C5 locations. If you are converting a split IF to a common IF, C3 and C5 may or may not be already installed. Select the coax you wish to keep as the common and connect it to the common input of K1.

### **PTT-H and PTT-L**

The TC has the option of either using a PTT-H or PTT-L keying circuit. The PTT-H requires +1.5 to +18VDC to activate it and will sink up to 2 mA. If using this circuit, be certain that the sink current will not exceed your transceivers rating. The PTT-L circuit requires a connection to ground to be activated. It is connected to the K1 relay and will source up to 25 mA to ground when keyed. If this exceeds your transceivers rating you may modify the TC as shown in our design note DN0?? Found in our library on our web site or call for a copy.

### **PTT Keying Through the IF Coax:**

Some transceivers such as certain models of the Yeasu FT290 supply a positive voltage on it's RF output connector during transmit or receive. This voltage may be used for keying the transverter. After verifying or modifying your transceiver for this function, the transverter may have the option installed. Select a choke of 1.0  $\mu$ h or larger and install it in the L1 position of the TC. Then connect a short wire jumper from the DC side of L1 to the PTT-H connection. When the transceiver is keyed, the voltage in the coax will key the PTT-H of the transverter. This is the most fool proof connection of the PTT line that can be made with any transceiver and is highly recommended by DEMI.

If the PTT-L connection is connected to the PTT connector, it will not affect the operation of the system. Just do not key both lines at the same time! If you will never use it, it may be disconnected and the external connector may be used for any other auxiliary connections.

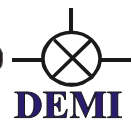
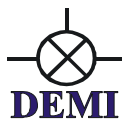

### **+DC Switching Functions:**

Relay K2 controls all of the +DC switching functions in the transverter. One side of the relay switches the raw +DC supply voltage to the transverter and the other side switches the regulated +9 volts. There are extra connection holes on the PCB if you require any additional switched voltage. Be sure not to exceed the 1.5 amp limit on the 9 volt regulated supply. The transverter's current drain is listed on its configuration page and allow for some overhead when the oscillator is not warmed up.

The switched voltages may be used for external LNA's, switching circuits for power amplifiers or relays. You may need to add an extra hole for a connector if the AUX connector is used. Be sure to fuse any external connections. The relay's contacts (K2) are rated for 3 amps.

### **24 Volt Relay Driver:**

The TC is designed with a 24 Volt relay driver. A brief explanation of the circuit is as follows. When the TC is in the receive mode, a 330  $\mu$ F capacitor is charged to the raw input voltage of the transverter (12-14 VDC). When the PTT circuit is activated, K3 switches this charged capacitor in series with the TXON voltage and outputs a brief spike of 24-28 VDC at the +R connection on the TC board. Depending on the current drain of the connected circuit (or relay), the charged capacitor bleeds off down to the raw input voltage of the transverter. The spike is enough to energize most SMA relays and the raw transverter voltage is enough to keep the relay energized. This circuit will not work with all relays but will operate with all relays supplied by DEMI in the optional WTR kit. If you wish to use a relay with a higher current drain, the 330  $\mu$ F capacitor may be increased. Just be sure that the relay being used will stay energized with +12 VDC. This circuit will not operate latching relays unless additional circuitry is installed.

**PLEASE NOTE!** Even though this connection will bleed down to the raw voltage of the transverter, the circuit should never be used on any electronic circuit that will not tolerate a **+28VDC input!** It will damage most +12VDC circuits. It will also not operate any circuit requiring voltage greater than the transverter's supply voltage other than a relay.

If a switched +VDC is required, move the wire from the +R connection (if installed) to either the +VTX, +RX, +9, +13RX, +13TX, or +13.8SW. Refer to the schematic for their functions.

### **RF Sensing Transverter Keying**

The TC is not designed to be a RF sensed switch. It has 3 relays and it may be connected to external mechanical relays. If any RF sensing scheme is added to the circuit, it will cause excessive relay chatter that will not only wear out the relays prematurely, but could cause other failures to external preamplifiers and or power amplifiers if used in your system. RF sensing circuits are not recommended with any circuit that contains mechanical relays at RF frequencies!!



### DEM TC Component List

C1 0.01 $\mu$ F	C10 2.2 $\mu$ F elect.	Q1 PN2222	R9 330 $\Omega$
C2 0.01 $\mu$ F	C11 2.2 $\mu$ F elect.	R1 220 $\Omega$	R10 5.1K $\Omega$
C3 0.01 $\mu$ F	C13 330 $\mu$ F elect.	R2 1K pot	R11 5.1K $\Omega$
C4 0.01 $\mu$ F	D1 -D6 1N4000	R3 220 $\Omega$	R12 330 $\Omega$
C5 0.01 $\mu$ F	IC 1 MAR6 ❶	R4 220 $\Omega$ ❸	2 - Red LED
C6 0.01 $\mu$ F	K1 G6Y relay	R5 1K $\Omega$	VR1 78S09
C7 0.01 $\mu$ F	K2 G5V relay	R6 220 $\Omega$	50 $\Omega$ load
C8 0.01 $\mu$ F	K3 G5V relay	R7 1K pot	1 $\rho$ F ❸
C9 100 $\mu$ F elect.	L1 1.0 $\mu$ h ❷	R8 220 $\Omega$	

❶ To by-pass IF gain stage, install 120pF in place of IC1.

❷ L1 is used with transceivers that have + DC voltage on RF line during transmit

❸ Depending on the drive level used, R4 may be replaced with a short, a 1pF capacitor, or a variable capacitor. See text for description.

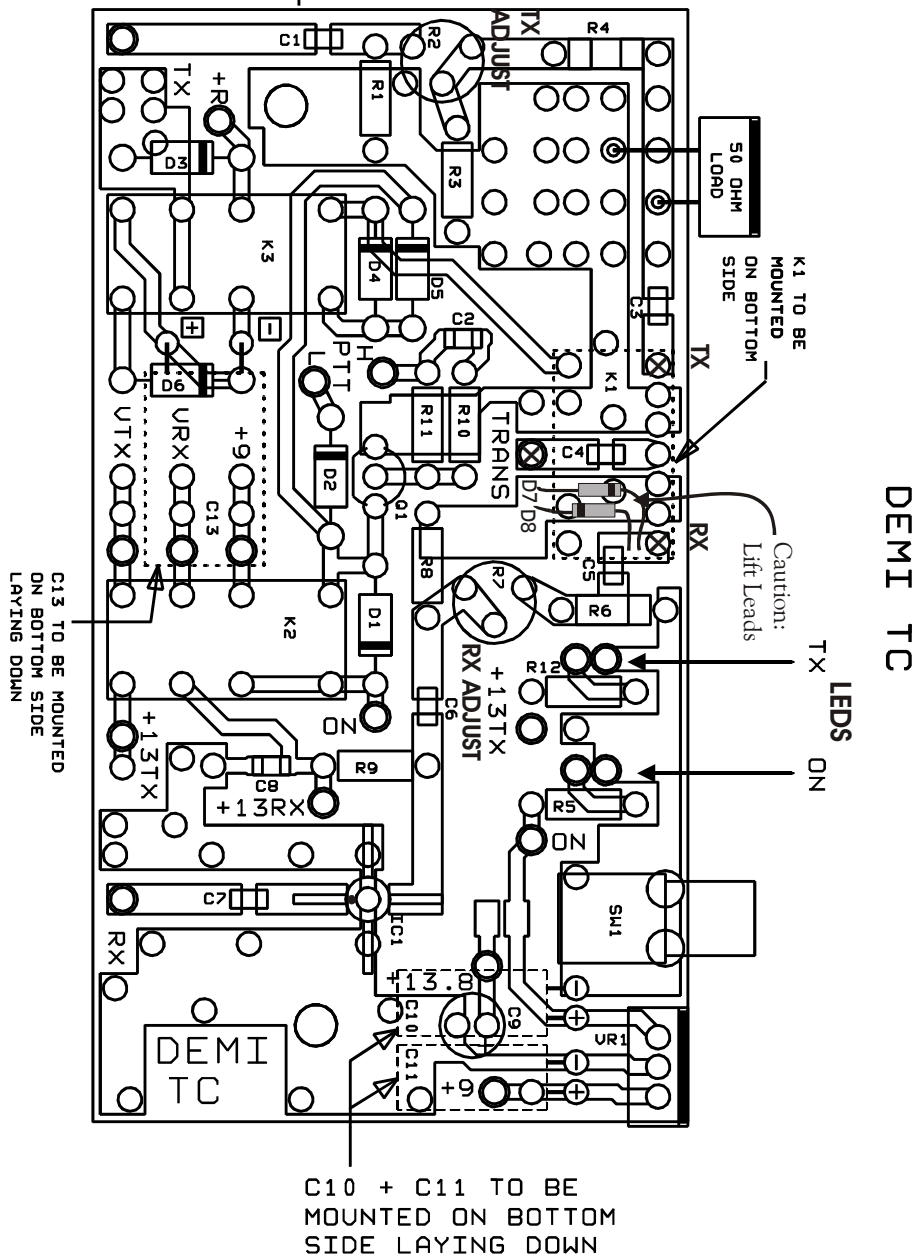

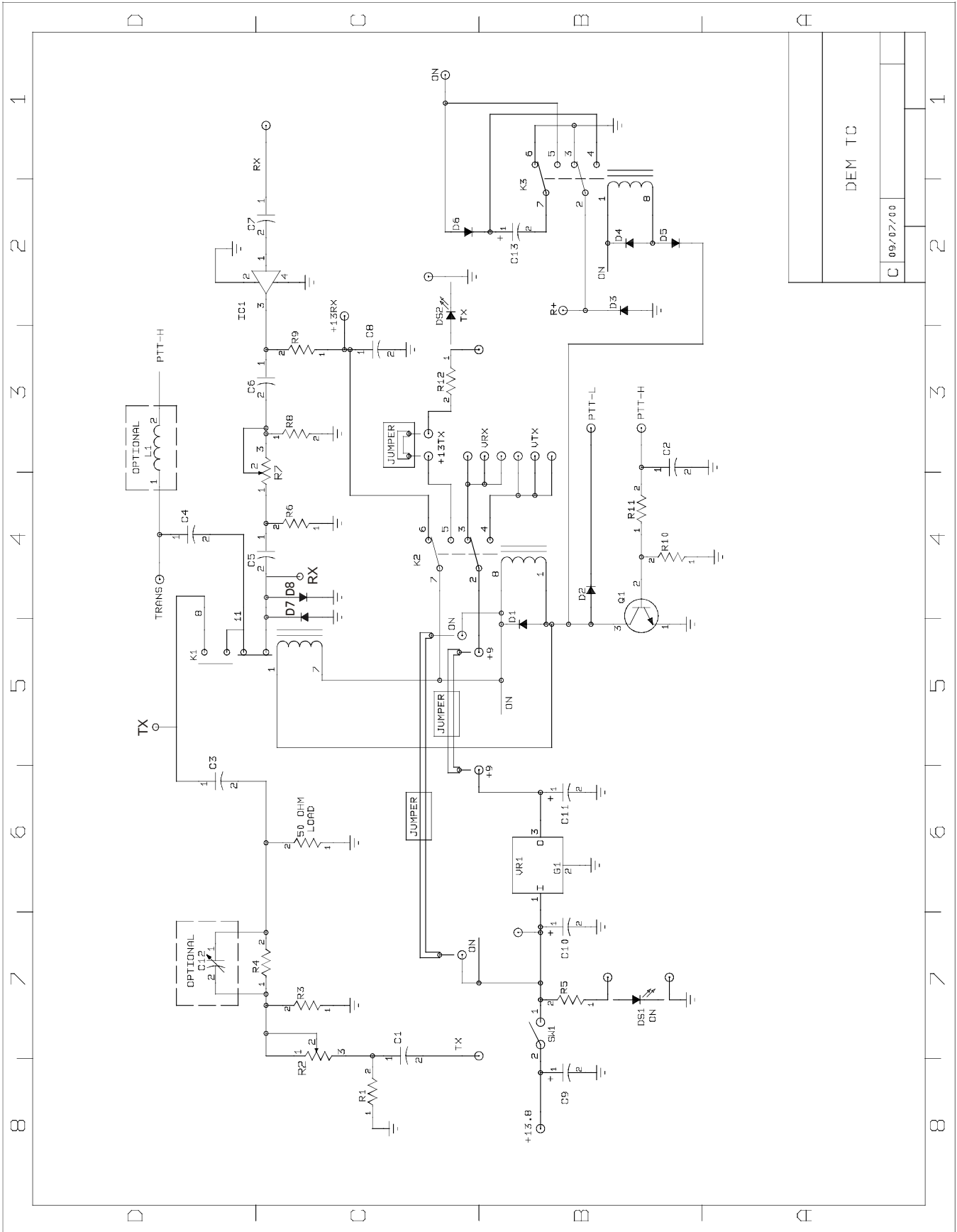

DEM TC	
C	09/07/00

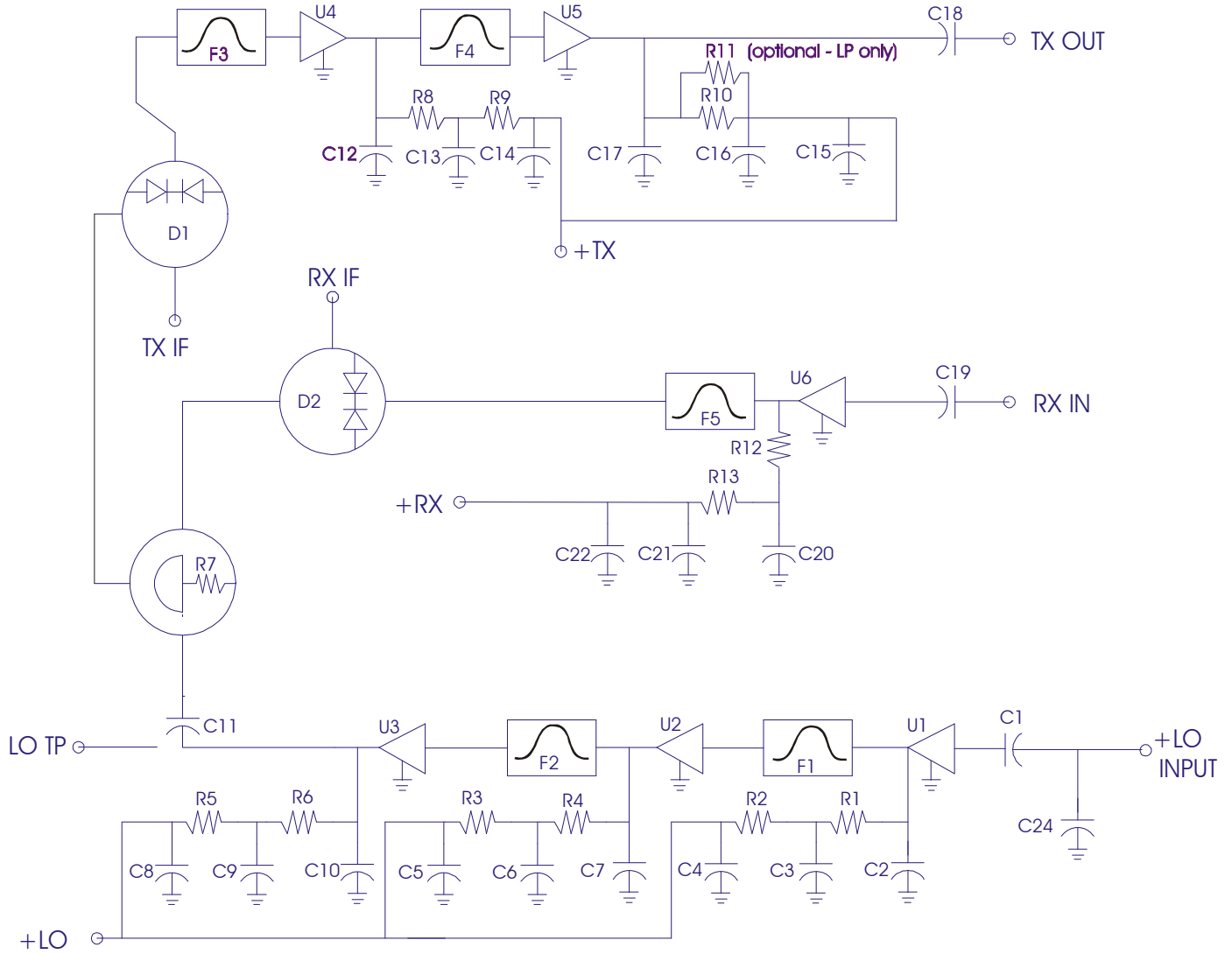

## 5760-144LP TRANSVERTER SCHEMATIC

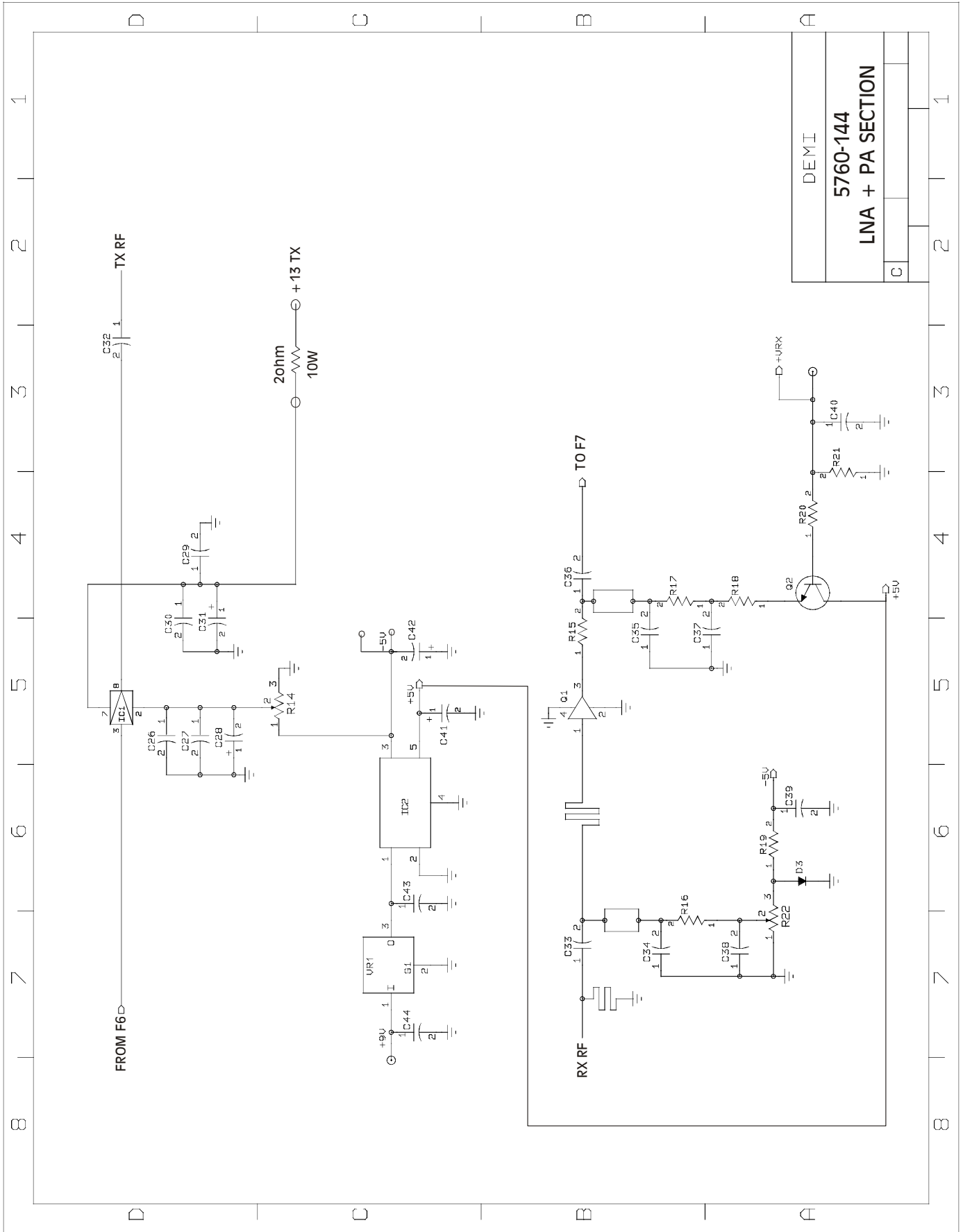



LP Version

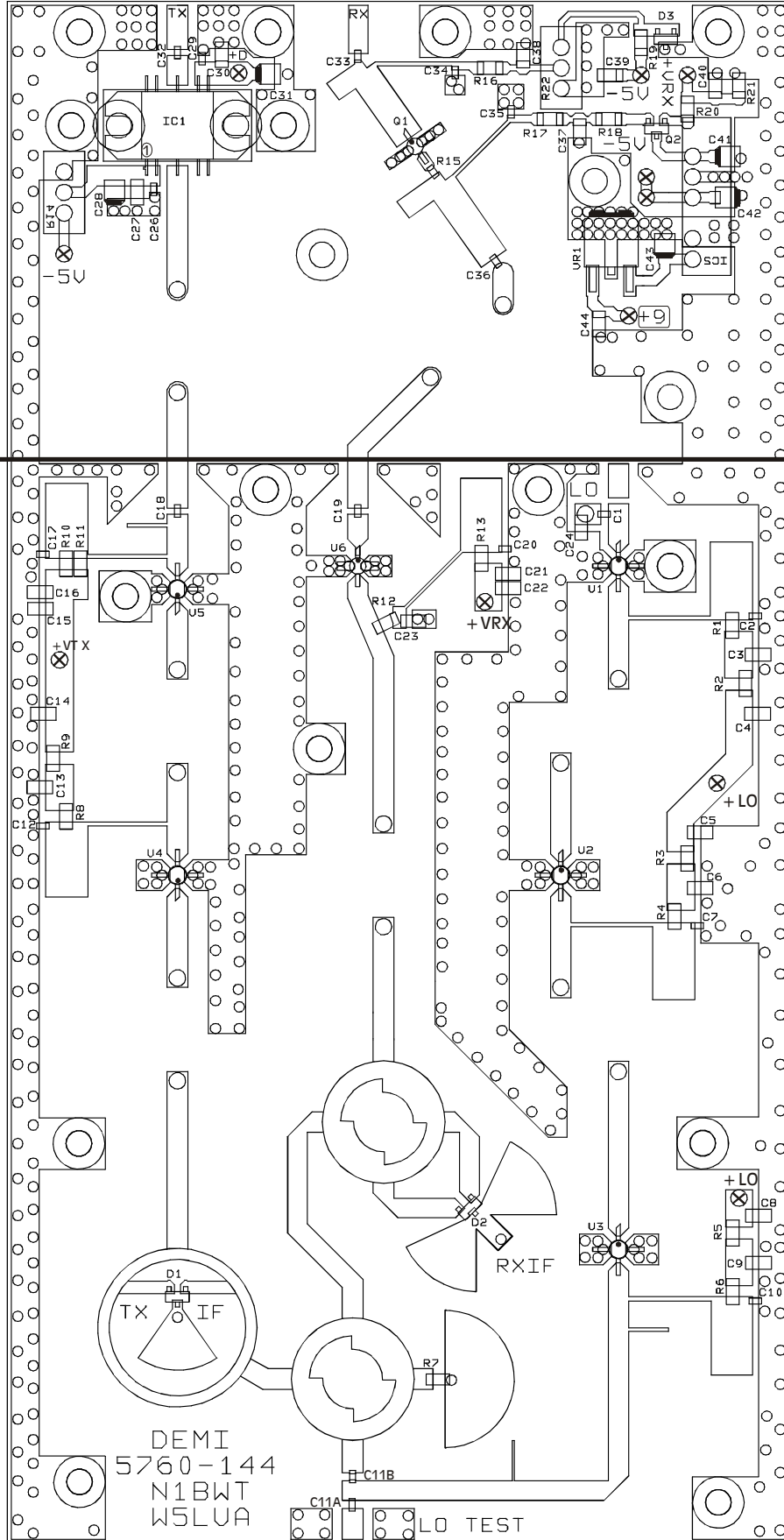

5760-144  
TOP SIDE ASSEMBLY