

**DEM Part Number 902/3 - 28H**\_\_\_\_\_

**90**\_\_\_\_\_ **MHz. Transverter,** \_\_\_\_\_ **MHz IF, SN**\_\_\_\_\_

Power Out Maximum:	30 W linear	60 W linear
Noise Figure and Gain:	1.5 dB maximum @ 17 dB conversion gain	
DC Power Requirement:	11.5 - 15.5 VDC @ 10 Amp	20 Amp
IF Option:	Common	Split
IF Drive Level Range Option:	-20 dBm – 0	1-100 mW 100 mW-1W 1-10W
Keying Option:	PTT - to ground	TTL - Positive Voltage
Aux. Connection Output Option:	TX	RX High Low Open
Antenna Option:	Common (optional)	Separate TX & RX
Frequency Offset:	_____ kHz.	

**Operational Overview**

The DEM 902/3 -28H is a high power 33 cm to 28 MHz transmit and receive converter. It has linear output power of 30 or 60 watts and depending on the drive level option chosen; it may be achieved with as little as -20 dBm mW or a maximum of 10 W. This transverter is a combination of our standard 33 cm transverter and one of our new 33 cm power amplifiers. The transverter's receive section uses a PHEMT that has a high-pass tuned input circuit biased for High IP3 output performance. It is followed by two helical filters, a high output IP3 MMIC gain stage, and a high level mixer with an IP3 output of +30 dBm. This design provides a sensitive low noise receiver with superior out of band signal rejection that will tolerate IP3 input signals > +5 dBm! The base oscillator of the local oscillator circuit is housed in a shielded enclosure on the circuit board. This shield coupled with the higher frequency base oscillator operation reduces the amount of spurious output while providing greater temperature stability. The transmit section has helical filtering to eliminate the troublesome LO and most spurious emissions. The two different power levels are achieved by MOS-FET hybrid power modules. The high power transverter can be configured for a common antennae or separate TX and RX connections. Auxiliary external switching connections are standard for DC switching of high power amplifiers, preamplifiers, or TR relays. The 28 MHz IF levels and options are adjustable on both transmit and receive with a dynamic range of approx. 20 dB. This adjustment combined with the relative power meter is useful for adjusting your maximum output power or setting the "S" meter level on your IF receiver. Options have been provided for a key line input PTT-H (+1 to 15 VDC) or PTT-L (a closure to ground). The PTT and auxiliary connections are via RCA jacks. The IF connections are via BNC connectors. The 33 cm connectors are Type 'N' only. The enclosure and heat sink for both models measure approximately 3.5 " high by 7 " wide by 9.75 deep and are painted in our standard rugged gray.

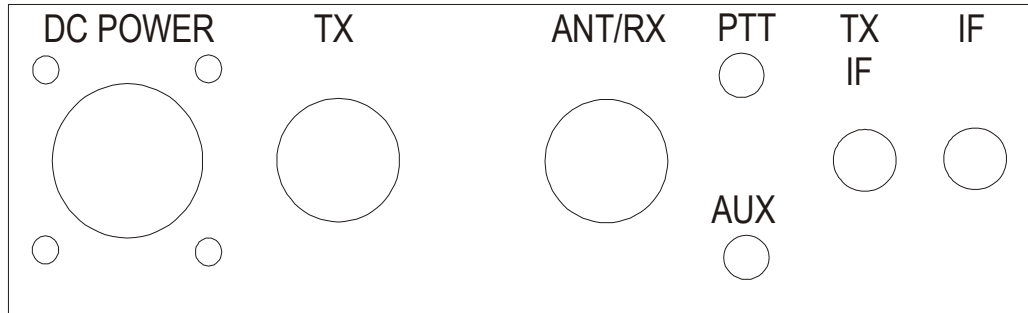
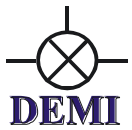

**Rear Panel view**

**Connect your transceiver to the transverter:**

Interfacing the transverter to the transceiver is easy. First, review the front page configuration. If the transverter was configured for direct connection to your transceiver, (10 watts or less) follow the steps listed below. If you plan to use this transverter with any of the DEMI transverter interfaces, follow the set-up instructions of that interface. If you have ordered a custom interface configuration, you already have an idea of what you are doing. Therefore, use the directions listed below as a guideline.

1. Connect all IF cables. The transverter may have a common IF port or two separate ports, TXIF and RXIF on the IF connector. Use good quality coax cable to connect the 28 MHz. ports between your transceiver and the IF connectors on the transverter.
2. Connect the "Push-to-Talk" line out of your transceiver to the transverter. It is a RCA connector labeled PTT on the transverter. Refer to the configuration sheet for the type of keying required.
3. If separate TX and RX ports were ordered, the internal transfer relay option has not been installed. The separate ports are labeled TX and ANT/RX. If you have the antenna relay option installed, the "ANT/RX" port has both TX and RX functions. Connect your 33 cm antenna system or a dummy load with a power meter to the appropriate 33 cm transverter ports.
4. Connect the DC POWER to the transverter. It uses a AMP type connector and is supplied with the matching cable. 13.8 volts is optimum but the transverter will operate normally from 11 to 15 volts. It has a 10 amp requirement for the 30 watt version and a 20 amps for the 60 watt. On the bottom of the transverter, preset the TXIF and RXIF gain controls in the transverter. Turn both controls fully clockwise. This is maximum attenuation on Transmit and minimum attenuation on Receive.
5. Power your transceiver "ON" and leave it in the Receive mode on 28.100 MHz. This should be 902/3.100 MHz. unless a frequency offset is indicated on the front page or you ordered a non-standard transverter.
6. Observe the noise level in the transceiver. If it is too high, adjust the RXIF gain control counter-clockwise until a slight noise increase is heard in the transceiver or just a slight movement in the "S" meter is detected. Power the transverter on and off to verify the change. The RXIF gain may be increased beyond this point, but it will start to degrade the dynamic range of your transceiver. Its all user preference. Find a signal on the band or use a signal generator to determine correct frequency, or minimum signal level. If you plan on installing an external LNA, this level will change.
7. It is now recommended to test the transverter's transmit section in the CW mode because most transceivers have carrier level or power level controls in this mode only. Do not use full or semi break-in if possible. Do not use FM, SSB or AM because it may not be possible to obtain

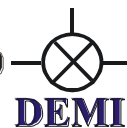
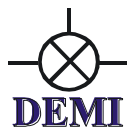

maximum output power with a transceiver in these modes. Set the carrier/output power control to minimum or "0" output power. Place the transceiver into transmit. If the PTT circuit is connected correctly, the transmit LED on the transverter will switch on. While observing the built in relative power meter or a 33 cm RF power meter, slowly increase the carrier control (with key down) or increase the power output control to the maximum IF drive level obtainable by your transceiver. If this is not what is indicated on the front page of this document, do not exceed that level by more than 20 % or if you find that the transverter is not correctly set-up for your transceiver's range, go to the "IF Options" section at the end of this page and re-configure the transverter before further testing.

If the transverter is configured correctly for your transceiver, minimal power may be detected on the power meter. Now slowly adjust the TXIF control in the transverter in a counter-clockwise direction while observing the power meter. Set it to any desired level between 0 and the maximum specified output power. The relative power meter is set to show 9 bars lit for the specified output power. This may vary with a bad VSWR but will be true into a 50 ohm dummy load. Switch the transceiver to USB and make a transmission. The power output and current drain should correlate to your speech pattern.

8. You may re-adjust both RXIF and TXIF again if desired. The receive amplifier and local oscillator frequency should not need to be adjusted but you may if you wish. Do not adjust any of the helical filters unless you have access to a spectrum analyzer at the minimum.
9. Your transverter system is ready to use. Connect as you wish to use it in your 33 cm system and have fun!

## **DEM 902/3 - 28 User Options and performance Improvements:**

### **PTT options:**

Both PTT-H and PTT-L can be changed on the topside of the board. The connections are located in the center of the board near the connector panel. Change the jumper as required from the PTT connection to either "L" (Ground to transmit) or "H" (Apply positive voltage to transmit)

### **Add an external preamplifier for noise figure improvement:**

If a better noise figure is desired, simply placing a LNA with a modest gain at the antenna will solve that problem. Understand that the addition of gain in front of this stock transverter will degrade the IMD performance, and reduce the dynamic range of the transverter by more than the amount of gain added. You may get away with doing nothing more than adjusting the RXIF gain control if you operate in a non-hostile RF environment. If your LNA is a ultra low noise unit, it most likely will not have the IP3 performance the transverter has. It will overload before any component in the transverter will. So, your receive system now becomes limited by it's external LNA's performance. If you increase the gain performance of your external LNA, (25-30 dB) you may consider bypassing the transverters LNA completely because it's IP3 performance is totally controlled by the external LNA. To do so, remove L9, R31, and R30 from the circuit. Then remove the RX coax from the input position and connect the center conductor to the pad of C63. Be sure to keep it as short as possible and solder the shield to ground.

Another option is to remove the IF amplifier. If you need to reduce the gain by less than 10 dB, remove IC5 and R18. Then using a 1000 pF disc capacitor, place it across where IC5 was. You may then adjust the RXIF control to your desired level.



## **Install / Remove RXIF gain stages:**

This was briefly discussed in the external preamplifier section. For whatever reason, you may require additional gain or have too much IF gain. IC5 can be installed or removed at any time. Be sure of your systems performance when deciding to make a change. You are also not limited to the supplied ERA 6 MMIC. You may choose a higher gain unit. The ERA 6 was chosen for its IP3 output performance. Using this MMIC doesn't degrade the transverters overall performance. A higher gain MMIC will reduce the IP3 performance by the difference in gain and will also degrade the system if a lower IP3 output device is used. In the future, this MMIC will change as soon as something better becomes available.

If changing or removing the MMIC, be sure to add or remove the correct choke or bias resistor for the desired MMIC. The RXON signal is the same voltage that the transverter operates on so calculate the new bias resistor based on that voltage.

## **Add an external power amplifier:**

There are different means in which this can be implemented. First, determine if your transverter has a common or split RF ports. To add a power amplifier to a common port transverter will require two additional relays on the input and output of the amplifier to allow the receive signals to bypass the added power amplifier. If your transverter has separate RX and TX ports, you can add the power amplifier in the TX path and install one relay on the output. This option can be the least troublesome (less relays) and most cost effective. If you wish to change your transverter from a common to a split RF version, a TX connection may be installed directly to the PA section of the transverter with a connector installed in the rear panel or the transverter may be returned to the factory for the modification. Also, consider using additional filtering or adding an isolator to the system between the transverter and power amplifier for gain and spurious management.

## **Auxiliary switching contacts:**

The auxiliary contacts in the transverter are wired as indicated on the front page. Referring to the component placement and schematic, relay K2 is labeled C (common) NO (normally open) and NC (normally closed). The contacts are marked for the receive mode. The C connection can be wired to ground or positive voltage such as the source +13.8 VDC. The K2 common connection will then be toggled depending on what state the transverter is in. The NO or NC can be wired to the AUX connector on the enclosure for keying additional power amplifiers, relays and other equipment in your system. The contacts are rated for 3 Amps @ 24 VDC

**IF options:**

The IF configuration of this transverter is listed on the front page. If you desire a different configuration, it may be changed. All possible IF configurations are shown below in the supplied schematic and simplified component layout. Follow the schematic and parts matrix list for desired drive level ranges if you require a different configuration or drive level. Splitting the IF to separate TX and RX is diagramed in the simplified component layout below. Other combinations and drive levels may work but do not exceed 10 Watts of drive level! The 50 Ohm load is rated for 30 watts but only on a heat sink.

	1-100mW Drive	100mW-1W Drive	1-10W Drive
C72	Not Installed	Not Installed	1pF
R36	Not Installed	50Ω, 30W	50Ω, 30W
R22	Install Short	220Ω, 1/4W	Not Installed

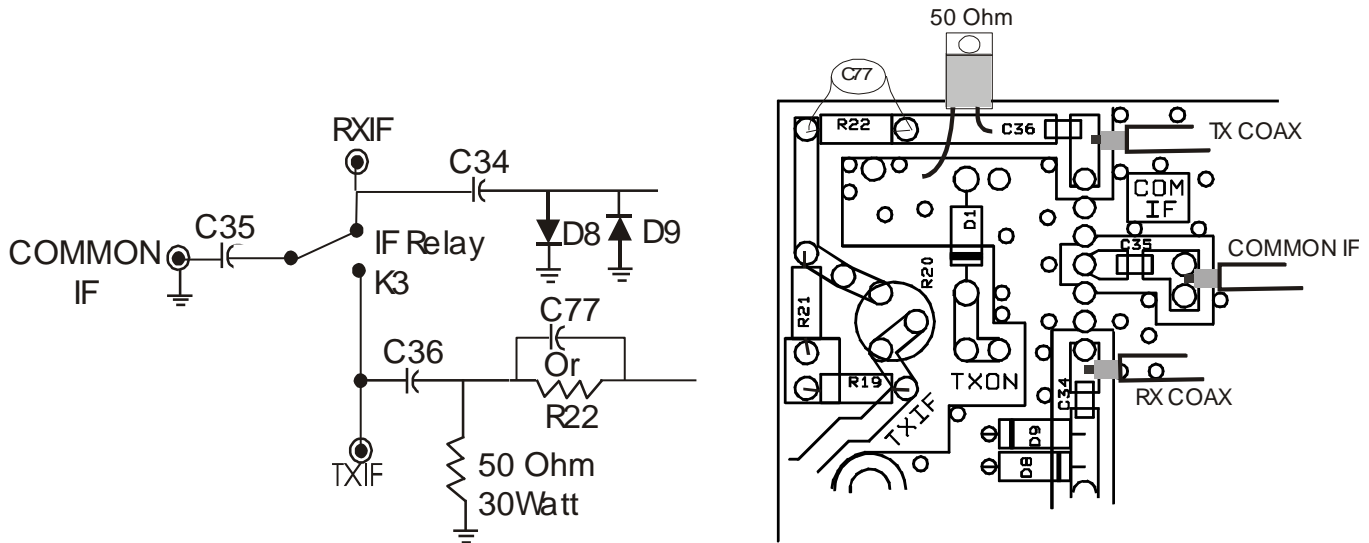

**Common or Split IF Configuration**

**DEM 902/3 -28H Component List**

**Resistors (R) values are in Ohms and are chips unless otherwise specified.**

R1 470	R11 51	R22 220 1/4W leaded OPT	R32 51
R2 470	R12 1K 1/4 leaded	R23 1K 1/4W leaded	R33 24
R3 1.5K	R13 220 1/4W leaded	R24 330 1/4W leaded	R34 5.1K 1/4W leaded
R4 100	R14 1K POT	R25 150 1/2W leaded	R35 5.1K 1/4W leaded
R5 51	R15 220 1/4W leaded	R26 330 1/4W leaded	R36 24
R6 100	R16 330 1/4W leaded OPT	R27 51	R37 12
R7 100	R18 150 1/2W leaded OPT	R28 100	R38 12
R8 130	R19 220 1/4W leaded	R29 24	R39 470
R9 130	R20 1K POT	R30 12	R40 470
R10 56 1/2W leaded	R21 220 1/4W leaded	R31 51	



**Capacitors (C) values are in pF and are chips unless otherwise specified.**

C1 0.1μF (1210)	C22 18	C43 0.1μF (1210)	C63 33
C2 1 - 4 Piston	C23 120	C44 33	C64 0.1μF (1210)
C3 0.1μF (1210)	C25 1000	C45 33	C65 33
C4 18	C26 1000	C46 0.1μF (1210)	C66 1.0 μF Tant.
C5 22	C27 100	C47 33	C67 0.1μF (1210)
C6 0.1μF (1210)	C28 100	C48 33	C68 0.1μF (1210)
C7 1000	C29 1000	C49 33	C69 33
C8 0.1μF (1210)	C30 0.1μF (1210) OPT.	C50 8	C70 33
C9 33	C31 1000	C51 0.1μF (1210)	C71 1000
C10 1.0 μF Tant.	C32 1000	C52 1000	C72 1.5 pF
C11 0.1μF (1210)	C33 0.1μF (1210) OPT.	C53 1000	C73 33
C12 33	C34 1000	C54 8	C74 33
C13 33	C35 1000	C55 33	C75 0.1μF (1210)
C14 0.1μF (1210)	C36 1000	C56 1000	C76 1.0 μF Tant.
C15 0.1μF (1210)	C37 1000	C57 A,B 33	C77 1.0 pF leaded
C16 33	C38 100μF leaded	C58 33	C78 33
C17 33	C39 33	C59 A or B 0.3-3 VAR.	C79 1000
C18 33	C40 1.0 μF Tant.	C60 0.3-3 VAR.	
C20 1000	C41 33	C61 100pF ATC	
C21 39	C42 33	C62 100pF ATC	

All inductors are specified. #24 and #28 is enamel wire size. Identify the molded chokes by body color and band colors. All others are as indicated.

L1 4 Turns 1/8" ID #24 Wire (HW)	L8 4 T BLUE (pre-wound)
L2 0.12 μH (Small body, Brown/Red)	L9 12 ηH (0603 chip inductor)
L3 0.33 μH (Small body, Orange/Orange)	L10 6 BLUE (pre wound)
L4 0.33 μH (Orange, Orange) (28 Mhz Bag)	L11 0.22 μH (Red, Red)
L5 12 Turns #28 Wire on T25-10 Toroid	L12 1.0μH (Brown/Black) OPT Brown Body
L6 1T, BLUE (pre wound)	L13 0.22 μH (Red, Red)
L7 A or B 2T, RED (pre wound)	1/8" wooden dowel

Q1 2N5179	F1 2770	IC11 MAR 6 OPT.
Q2 2N5179	F2 2770	IC12 AH215
Q3 FPD 750	F3 1260	VR1 78S09 or 7809
Q4 KN2222	F4 2737	VR3 78S05 or 7805
D1 1N4000 type	F5 2737	VR4 78M05
D2 MPN3404	IC1 ERA 3	K1 G6Y-1 or G5Y-1
D3 MPN3404	IC2 ERA 2	K2 G5V-2
D4 HSMP 3814 or 3824	IC3 MAV-11	K3 G6Y-1 or G5Y-1
D5 1N4000 type	IC4 SYM-14H	PTC1 PTC 60 Thermistor
D6 1N914	IC5 ERA 6 OPT.	Y1 Crystal 174.800MHz
D7 1N4000 type	IC6 MAR 3	Crystal Brass Shield
D8 1N914 OPT	IC7 MAV 11	
D9 1N914 OPT	IC10 GALI 74	

### Amplifier Section

The amplifier section is shown below as the 30 watt version. For the 60 watt unit, duplicate the components listed below. There may be additional grounding built into the PCB. There may also be a shield attached. The single hybrid will require 5 mW from the transverter board to achieve the HP transverters rated output power. For this reason, there may be an additional attenuation installed on the transverter board. This will depend on the gain of the RA20H8994M hybrid. They vary as much as 10 dB! Additional RF circuit adjustments to the power amplifier circuit may have been made to increase output power, improve input matching, or increase DC power efficiency. Additional beads or RF chokes may also be installed.

#### Component List

C1	100pF nominal. See chart	C10	0.1 μF chip	U1	Power Module
C2	0.1 μF chip	C11	100 ρF chip	U2	78L05
C3	100 ρF chip	R1	50Ω Load <i>optional</i>	Q1	MPSW51
C4	100 μF elec.	R2	<i>Optional 330Ω</i>	D1	HP 2800
C5	0.1 μF chip	R2	<i>Optional 470Ω</i>	C1	0.3-3pF trimmer
C6	100 ρF chip	R3	51Ω chip	C1	1pF Chip
C7	330 μF elec. 25V	R4	1KΩ chip		Module RF shield
C8	1.0 μF Tant chip	R5	1KΩ chip		
C9	0.1 μF chip	R6	1KΩ chip		

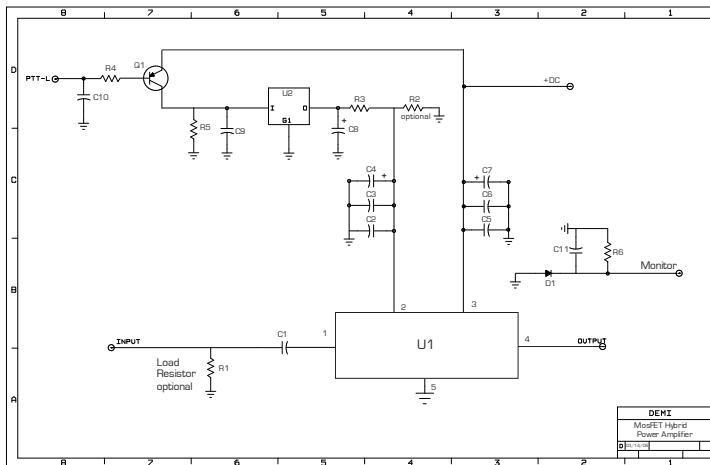

- Pin Out**
- 1 RF In
  - 2 Bias (TXON)
  - 3 Vcc (+13.8VDC)
  - 4 RF Out
  - 5 RF & DC ground (Flange)

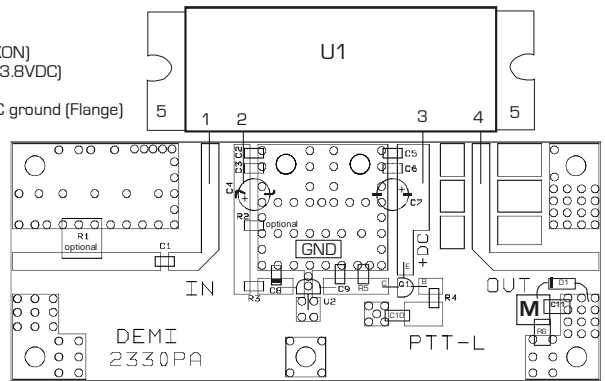

### 50 Watt Version

The additional components required for the 50 watt version are 50 ohm loads and two “wire line” combining circuits. The loads may be single piece units or made up of chip resistors. The circuit board will look different but are electrically the same with the accommodating pads to install the wire line combiners and loads. Additional circuit adjustments may have been made for grounding and overall performance.

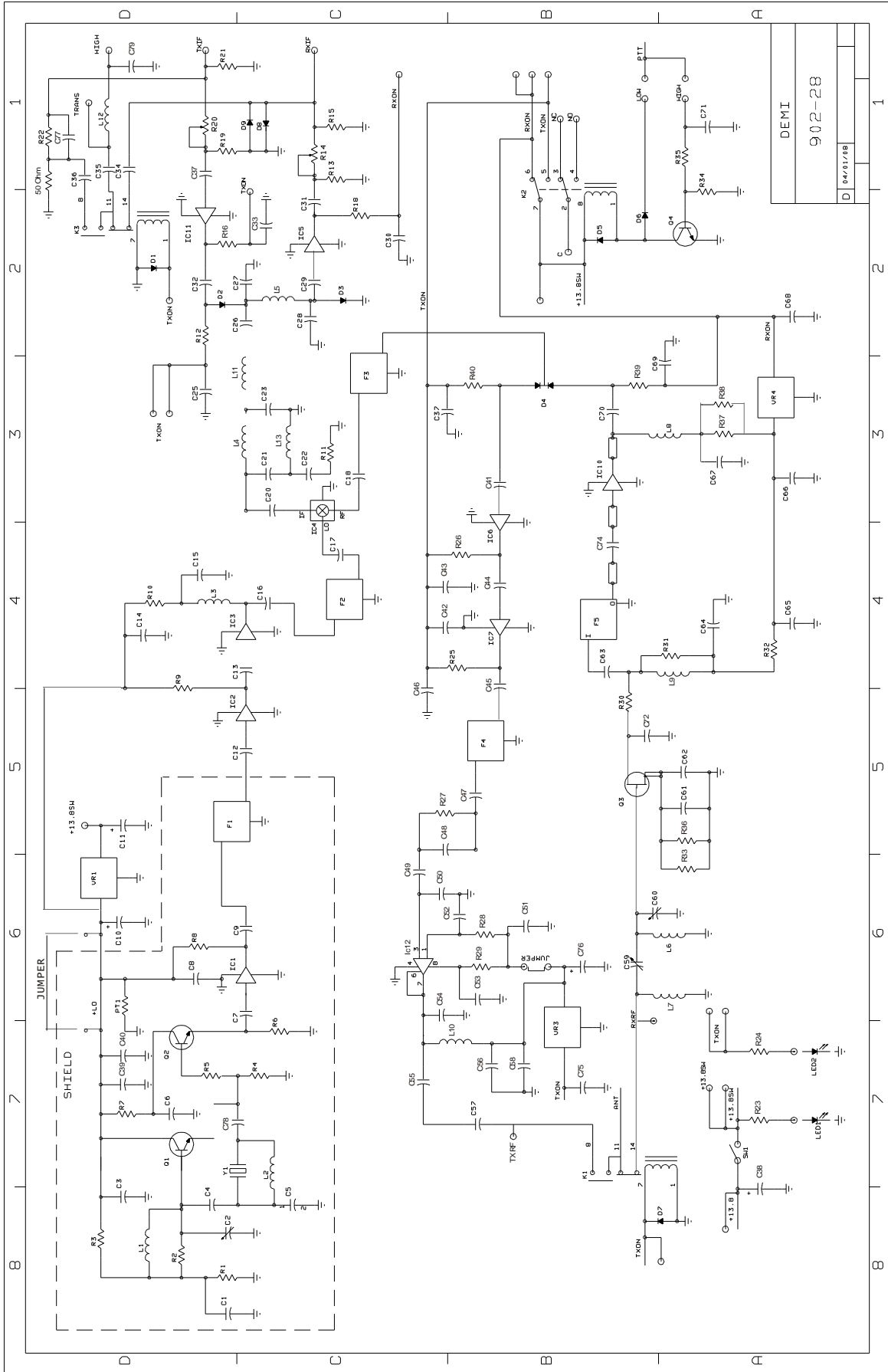

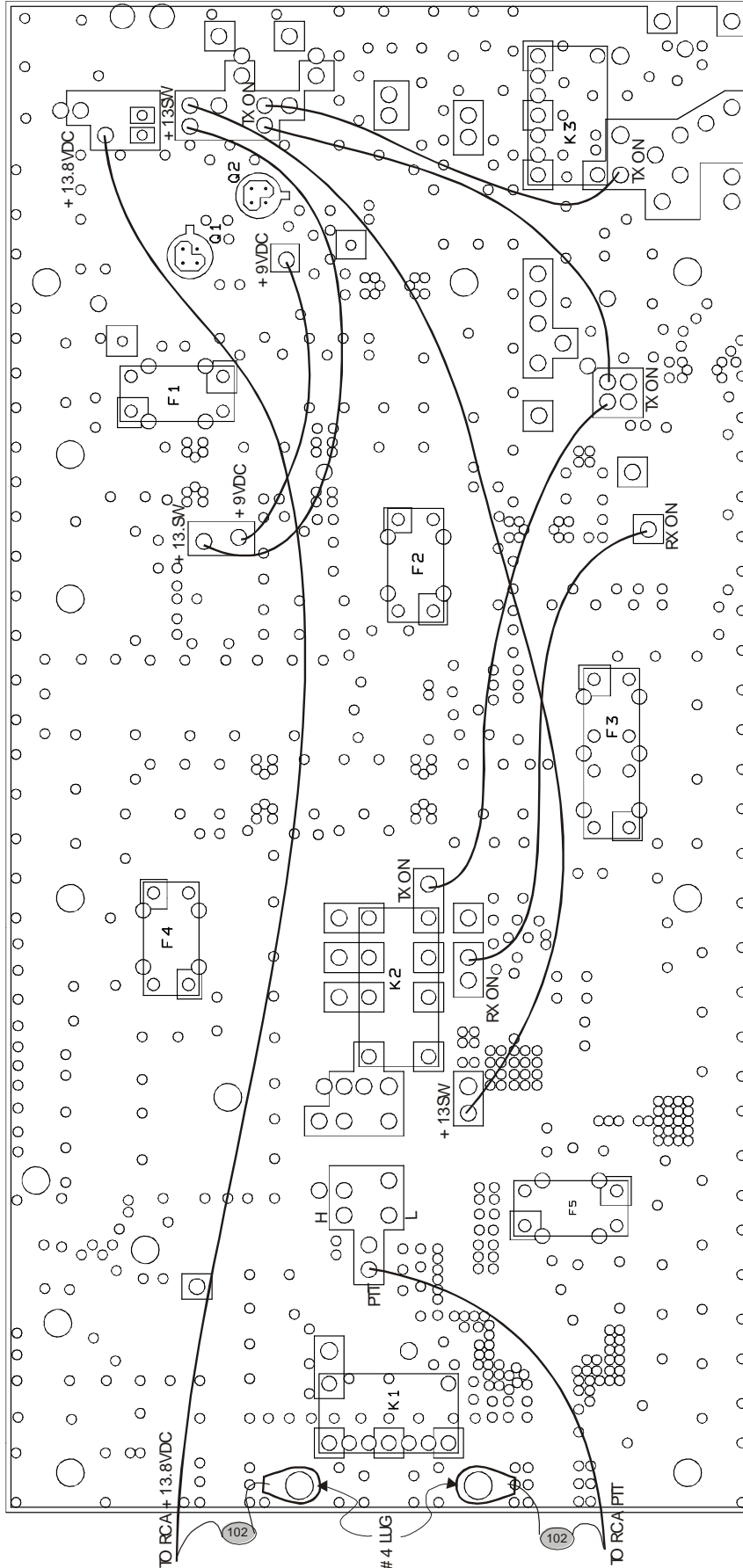

# 900 Mhz Bottom Assembly

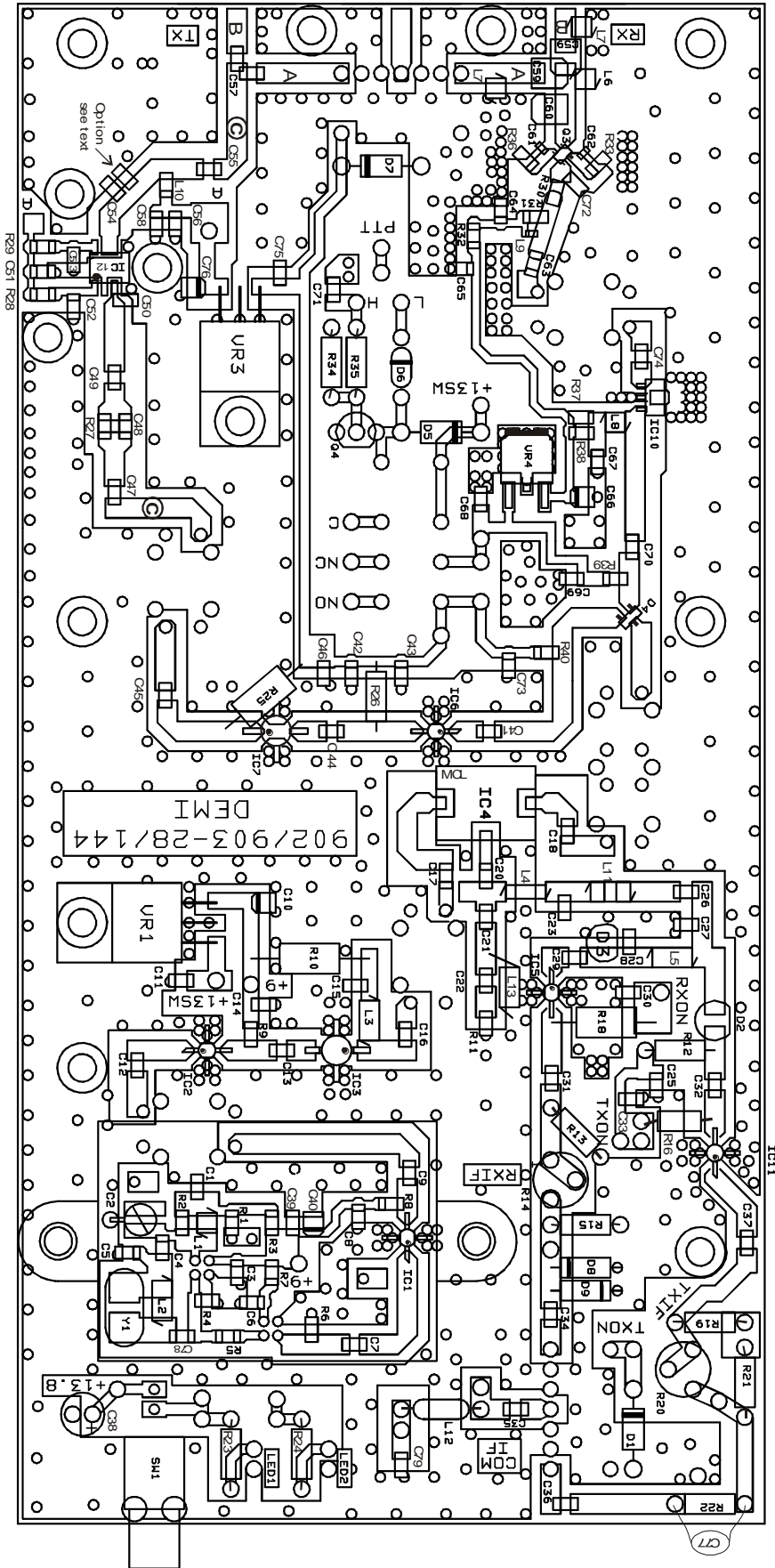

902-28 COMPONENT ASSEMBLY