



DEM ABPM All Band Power Meter

10 KHz to 10 GHz low level power meter

PREFACE:

The DEM ABPM is the all band, portable power meter developed by W1GHZ and described on his web site at http://www.w1ghz.org/new/DEM_ABPM_kit.pdf It is recommended reading before you start assembly of this kit. The paper titled "Portable RF Sniffer and Power Meter" discusses the compilation of designs by W7ZOI, W7PUA, WW2R, and W1GHZ then explains the evolution of the final product. The web page explains the circuits in detail providing individual test data of the power detector circuits. The page also discusses the methods of calibration, and the final use of the circuit when complete. Be sure to review the references at the end of the web page for further technical information and data sheets of the power detector chips. Other circuit designs are available at that site that will compliment this kit. Feel free to browse around for other ideas.

CIRCUIT DESCRIPTION:

Now called the DEM ABPM in the Down East Microwave Inc. catalog, are actually two individual power detection circuits combined through a simple switch connected to a bar graph voltage meter. It is all neatly place in an enclosure with a self contained battery to make a complete portable RF power detecting device that fits in your pocket. The ABPM has two individual inputs (SMA connectors) that are limited by the frequency response of the detector chips they are connected too. The Bar graph display can be operated as a running bar graph or as individual ascending / descending segments to conserve battery power. The ABPM also has an external meter connection so that more precise "measurements of change" device may be used by connecting a digital or analog voltmeter directly to the detector circuits. One of the references on W1GHZ's web site describes an audio tone indicator and how it can be used with this device.

As for the kit in general, all components, hardware, connectors, and assembly instructions are the responsibility of Down East Microwave Inc. Please call us if you find any components missing, broken, or incorrect. Please do not contact W1GHZ with complaints such as fit and form or missing or damaged components. He is not employed by DEMI and has no control of the contents of this kit. DEMI has agreed to compile and distribute this kit with the original circuit board and components available from the DEMI standard inventory. If you wish to discuss circuit functions, modifications, or further uses of the circuit, Paul will be happy to, If contacted through his website at www.w1ghz.org. with any details concerning these matters. You may also drop him a line in regard to how you enjoyed this kit or any concerns on how DEMI is managing the distribution of this kit to the armature radio public.



CIRCUIT BOARD ASSEMBLY:

The circuit board assembly is basic and straightforward but some hints and special notes are worth paying attention too. Use only the schematic and component placement supplied with this kit for the best results. Some designators and placements have been changed from the details provided on the W1GHZ web site to accommodate the components actually used in this kit. Please review all of the following notes and read this document through before starting assembly.

Circuit Board:

1. Screen printing for U2 is backwards on circuit board. Follow the component placements used in this kit only!
2. Surface mount versions are used for C4 and C5. Their polarity is indicated on the component placement. The leaded version positions of both will be vacant when assembly is complete.
3. Connectors or header pins are not used for J3 and J4.
4. R3, C7 and C9 are mounted on the bottom side of the PCB. U3 is shown on the bottom side placement for orientation of those components. U3 is mounted on the topside.
5. The bar graph is installed on the bottom side. Examine the display carefully. One corner is slightly chamfered to indicate pin one. The chamfer is shown on both components placements (top and bottom). The screening on the PCB does not indicate it.
6. U1, the LTC5508, will be the most difficult part to assemble in this kit. It is found in a foil bag. It has six leads. The lettering on it is most difficult to read but is imperative that you do for proper alignment. Once the IC is heated with any flux during soldering, the marking is removed making it next to impossible to verify. You get one shot at aligning it correctly.

Actual Assembly:

Use the component list with both top and bottom component placement diagrams.

1. Start by installing U1. Use a magnifying lens to verify lead placement on the PCB and the marking on the LTC5508 for alignment. Position and solder one outside leg only. Re-verify placement of leads on pads then solder opposite leg of IC. Be sure of placement then solder the other four leads. Use solder wick to remove excess solder that may bridge or bulge over. Clean with flux remover and test with ohmmeter for shorts. If you have a short try solder wick again. If you are required to remove the IC from the PCB to repair, it most likely will not survive. Call DEMI for a replacement.
2. Next, install the topside surface mount components.
3. Install U2-U4. Remember that the screening for U2 is backwards.
4. Install C8 with a 1 turn 3/16" loop in the lead that is installed in the pad that C7 and R3 are connected to. The loop is L1 on the schematic.
5. Install all other leaded components including VR1 and VR2.
6. Install bottom side surface mount components.
7. Install bar graph on bottom side. Remember the chamfer is pin 1.
8. Trial fit the SMA connectors before soldering (found in the hardware bag). You will need to trim the center pin length and modify the ground pins slightly. You will also need to remove some solder mask from the ground plane before soldering. Push the flange of the SMA up against the PCB as close as possible or the board assembly will not fit in the enclosure.



COMPONENTS LIST

Component Bag: Resistors values are in Ohms and are 1/4W leaded unless otherwise specified. "POT" = Potentiometer. "ELC" = Electrolytic. "Chip" is surface mount components.

C1	8.2pF 50mil ATC	C11	0.1µF leaded	R7	1.8KΩ
C2	100pF Chip (0805)	C12	100 µF ELC	R8	1.8KΩ
C3	0.1µF Chip (0805)	C13	0.1µF leaded	VR1	10KΩ Pot
C4	1.0µF Tant Chip	C14	0.1µF leaded	VR2	500Ω Pot
C5	1.0µF Tant Chip	R1	10KΩ	BAR 1	Bar graph display
C6	0.1µF Chip (0805)	R2	51Ω Chip (1206)	U4	LM3914
C7	15pF Chip (1206)	R3	470Ω Chip (1206)	U1	LTC5508
C8	1000pF leaded	R4	10Ω	U2	78L05 reg
C9	0.1µF Chip (0805)	R5	18KΩ	U3	AD8307
C10	0.1µF Chip (0805)	R6	470Ω	One	ABPM Circuit Board

Enclosure Assembly

Start by wiring the PC board using the wire chart provided below. Cut and tin all wires to length then attach them to the "From" positions on the circuit board. All wiring is done on the topside of the circuit board. There will be Red, Black, and some other color wire that is designated "odd". (Something other than red or black) Pins #1 of the J3 and J4 connectors are the holes on the circuit board in the square pads. Pins #2 are the round pads. For the GND connection on the circuit board, scrape some solder mask off the circuit board above the WW2R logo and attach it by soldering. Check all connections and trim excess wire off from the bottom.

Wire Connection Table

WIRE	SIZE	FROM	TO
#24 Red Teflon	3"	+V on PCB	ON/OFF switch
#24 odd Teflon	3-1/2"	J4-1	VHF/UHF switch
#24 odd Teflon	3-1/2"	J3-1	VHF/UHF switch
#24 odd Teflon	3"	J3-2	Jack
#24 Black Teflon	3"	GND	Jack
#24 odd Teflon	3"	J4-2	VHF/UHF switch
Black from Battery Clip	NA		-V on PCB
Red from Battery Clip	NA		ON/OFF switch

Find the half of the enclosure that has the battery compartment in it. It will also have three round holes on three different sides. Install the two switches and jack as shown. Then install the battery clip leads through a hole in the battery compartment side (not a top hole!) closest to the ON/OFF switch. Position the enclosure as shown on your workbench. Place the circuit board on the bench on the ON/OFF switch side of the enclosure with the wires up and the SMA connectors pointing in the same direction as the VHF/UHF switch. Do not install the circuit board in the other half as of yet. Connect the wires from the circuit board to the switches, jack, and from the battery clip as shown below. After wiring is complete, check all connections and verify all circuits by eye for shorts or wire clipping debris. If circuit board looks ready, attach it in the other half of the enclosure by aligning the SMA connectors with the holes in the enclosure then inserting the circuit board in place. Check to see that the bar graph display is correctly positioned in the machined hole of the enclosure. There is some play in the screw holes so the display could be misaligned. Attach the board with four sheet metal screws keeping the bar graph positioned correctly.

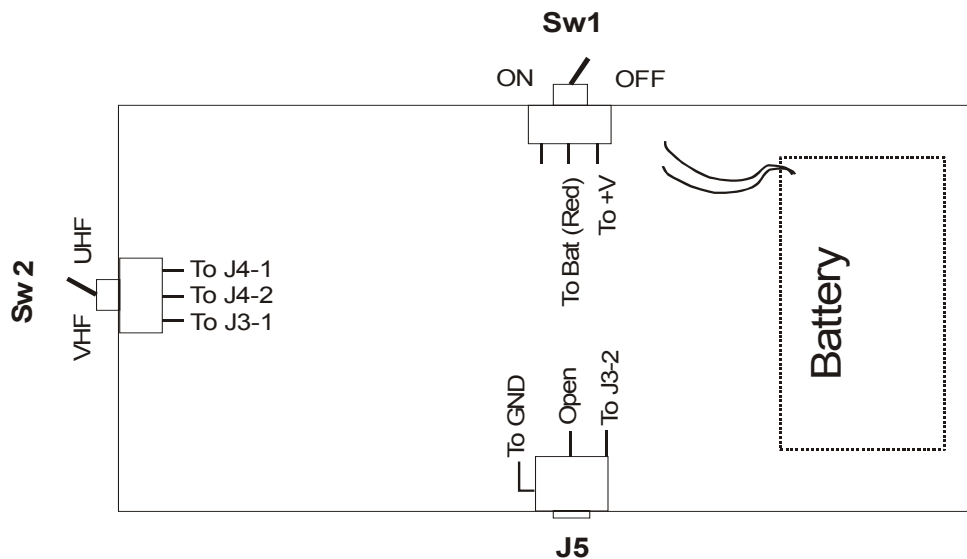

Battery Compartment Half

Hardware Bag Component list:

(4) #4 Sheet Screw	(2) SPDT switch	(3") Black Teflon wire
(2) 1-Hole PCB Mount SMA	(1) Battery Clip	(3") RED Teflon wire
(1) 2.5mm Plug	(1) 2.5mm Jack	(15") #24 Odd Color Teflon wire
(1) Machined Enclosure		

Testing and Operation:

If all connections are correctly made and a battery is connected, it should come to life. With the switch on, verify that the 5 VDC regulator is operating. Then follow the setup instructions as published by W1GHZ on his website.



The bar graph indicator is handy as a quick, no thinking required, indicator. Many times, that’s all you need. Since the sensitivity curves in Figure 8 are so different, some compromise is required for the LED bar graph to make sense for both detectors. The output of the AD8307 may be loaded down, by R5 in the schematic to adjust the slope of the response. I found that an 18K resistor gave similar full-scale readings for both detectors. I set the “ZERO” pot so that the first bar on the high-frequency side is lit, to provide a free pilot light, and set the “FULL SCALE” pot to light at +10 dBm. Then I measured the response of both sides at 144 MHz, shown in this Table:

BARS	Low Frequency	High Frequency
1	-70 dBm	—
2	-59	-15 dBm
3	-51	-10
4	-43	-5
5	-35	0
6	-26	+3
7	-18	+6
8	-10	+7
9	-2	+9
10	+5	+10

The LED indicator may be operated as a bargraph or as a series of dots, with only one LED on at time. Since each LED draws about 20 mA., battery life will be much longer in dot mode. The mode is selected by a jumper, JP1 on the board.

Practical ABPM Use :

As you use this versatile power indication device, you will find many uses for it during your portable operations or at home. It can be used to check low-level transverter port output power or used to measure low-level microwave transverter output. It may be used at higher levels with the proper attenuation installed on the SMA connectors. With a “sniffer” type antennae installed on the RF ports, it can detect transmit power radiating from an antenna system. You will find it to be most sensitive to any RF environment it is used in from 10 KHz to 10 GHz.

We hope you have fun assembling and testing this kit and hope you have continued fun with its use. Good Luck on the bands.

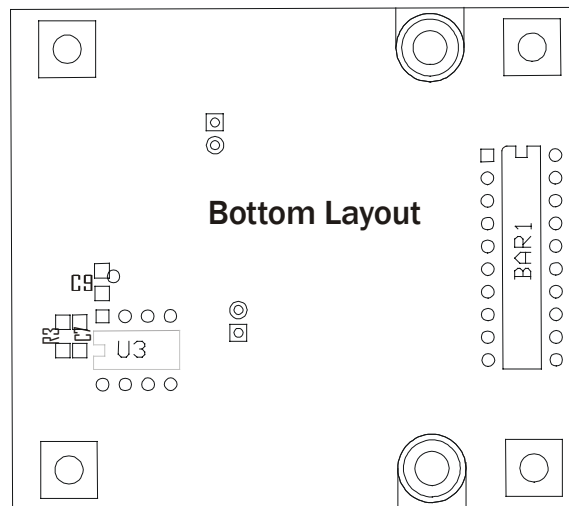
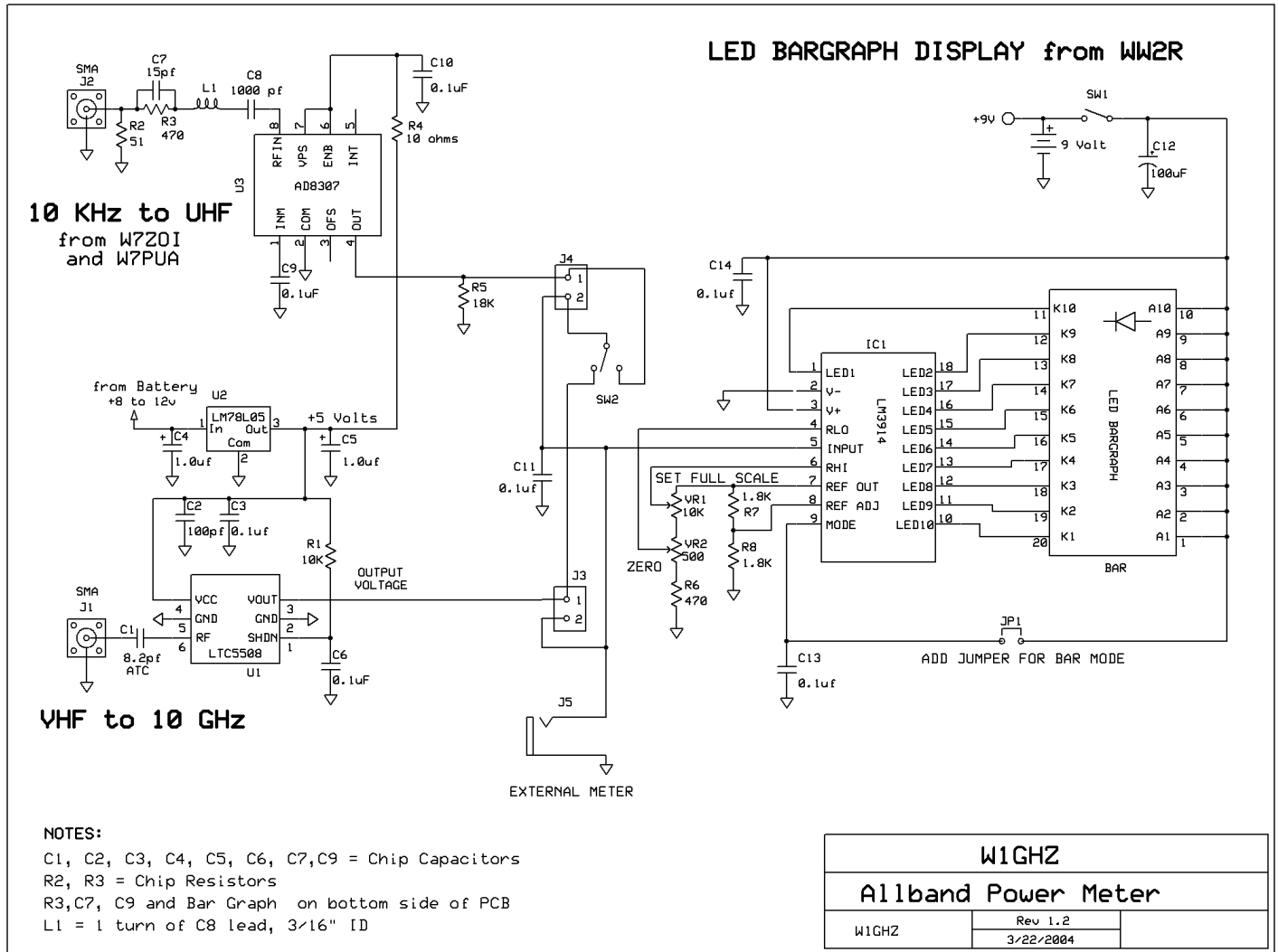

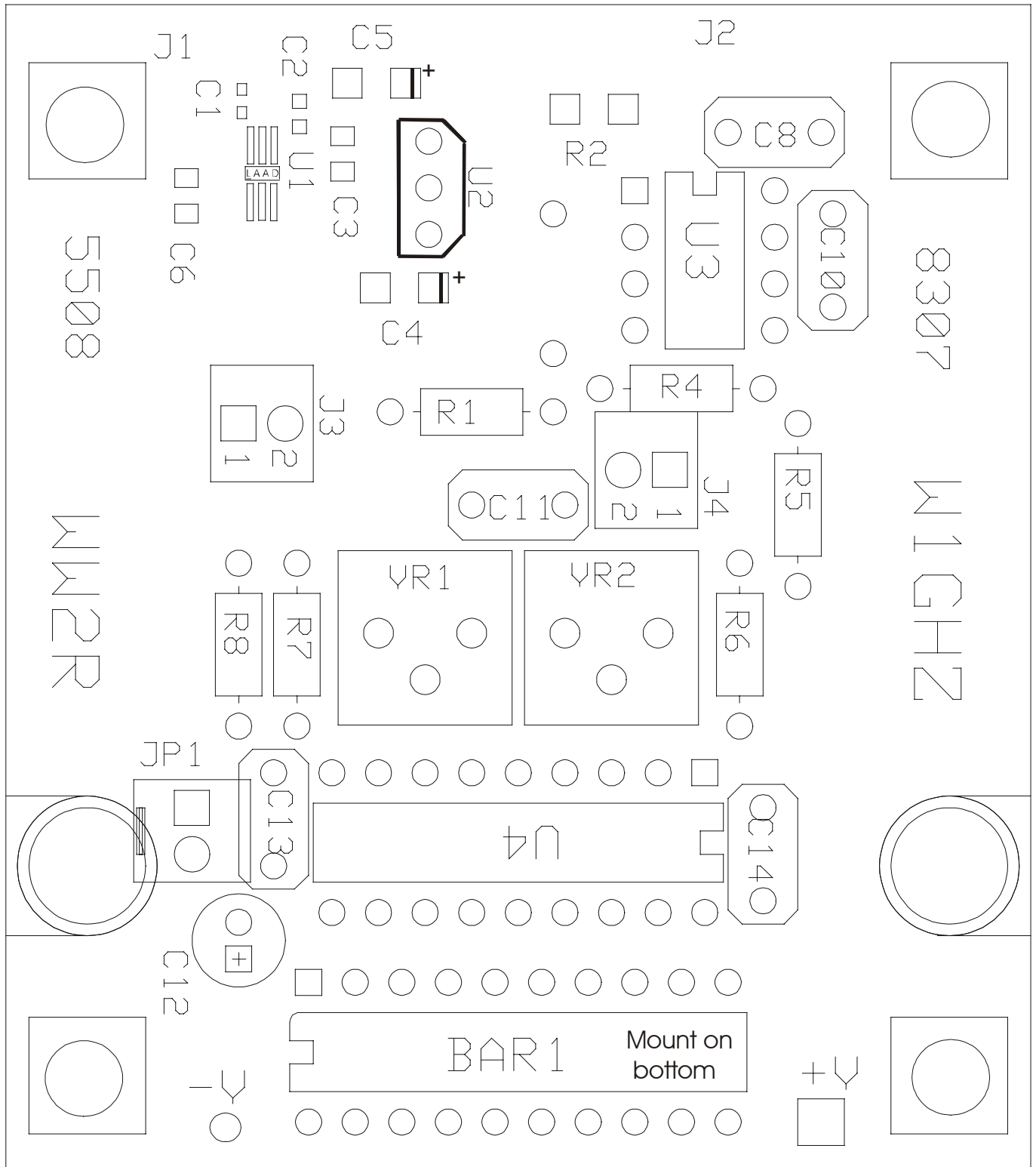

ABPM Top PC Board Layout