

DEM Part Number L33HP SN _____

902/903 MHz Transverter Set For _____

Power Out Maximum:	25 W linear	50W linear	
Noise Figure and Gain:	1.5 dB maximum @ 17 dB conversion gain		
DC Power Requirement:	11.5 - 15.5 VDC @ 10 Amp		
IF Option:	Common	Split	
Max IF Drive Level:	< 0dBm	+10dBm 100 mW 1W 10W	
10 MHz Source Level:	+3dBm +/- 6db (Always terminate the port when not in use)		
Antenna Option:	Common	Separate TX & RX	
Transmit Enable: Pin 5	Ground	Positive Voltage	
Other Options: Pin 4			
Pin 9			
Sequencer:	Enabled	Disabled	
Sequencer Outputs:	Transmit	Receive	Color
Pin 1 (Sequencer step 1)	Open	High (750ma)	
Pin 2 (Sequencer step 2)	High (750ma)	Open	
Pin 3 (Sequencer step 3)	Low (100ma)	Open	
Pin 6 Ground	Ground	Ground	
Pin 7 Ground	Ground	Ground	
Pin 8 Ground	Ground	Ground	

Other notes:

Operational Overview: This is the newest version of Down East Microwave's 33 cm Transverter. It is a complete new design in a smaller package utilizing the latest in MMIC amplifier and SAW filter technology coupled with a standard low phase noise synthesizer for frequency accuracy and stability. This technology allows a "No-Tune" performance and function enabling the user to select a different IF frequency range (10, 6, or 2 Meters) if desired. This design also includes other improvements over past



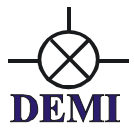

versions by offering a 4 step sequencer, and at 25 and 50 watt output power levels. Additional options include a mast mount preamplifier control that is sequenced if desired, and remote DC power control.

What is the same as the past is the RF and IF configurations and drive level options. The transverter may be configured with common or split IF at any drive level between -20dBm to 10 Watts. This can be changed easily at any time. All IF connections are made through standard BNC connectors. The RF configurations are separate TX and RX ports or a common RF. An onboard relay is standard and may be reconfigured at any time. The RF ports are type N connectors only. Keying the transverter is done by either a voltage (PTT-H) or a ground on transmit (PTT-L) through the AUX connector which also houses the Sequencer outputs and additional options. All DC and AUX cabling is supplied.

Configuration Overview: The DEM L33HP transverter is designed to interface to all modern amateur radio transceivers but has been specifically configured to your transceiver's specifications. As indicated on the front page, some user options and configurations need to be selected before delivery and may or may not be user changeable. Let's review your configuration and verify that your interface will be easy and trouble free. Please refer to the front page chart for the following.

DEMI Part Number Verification: All DEMI transverters contain the operating band within the part number, i.e., L33HP equates to the 33 centimeter band. (902-928 MHz) Since this is the first transverter design that has a user selectable IF frequency, we simply indicate what the transverter is "Set For" under the Serial Number on the front page. The configured IF frequency is what we have on record as your request. If this is incorrect or your desires have changed, its not a problem and will be discussed in a section of this manual entitled "If Frequency Selection".

RF Output : Next is the maximum output power of the transverter should be operated at. It will be circled or indicated in the "**Other Notes**" section if a custom level was required. These levels are the **maximum linear** output power levels that should not be exceeded if clean linear operation is expected. In most cases, the amplifier is capable of higher output power but is not recommended because of excessive "on the air" distortion products.

Noise Figure and Gain: The noise figure and gain listed are the minimum requirements and all transverters meet or exceed these specifications. In utilizing the latest PHEMPT and SAW filter technology, we have designed the receive chain for the best performance balancing gain management, IMD performance, and noise figure to eliminate over load and out of band interference while maintaining a stable, quiet, sensitive receiver. .

DC Power Requirement: The DC power requirement is listed and should be used as a guideline. Please include some "Buffer" in your power supply to eliminate voltage drop delivered to the Transverter. If a custom lower power is requested, a lower current power supply may be utilized. Always choose the correct level of fusing for protection.

IF Option: The IF option has two choices. A "**Common**" IF connector which both TX and RX IF frequencies are conducted through a single connector or "**Split**" IF connections with a separate connector for the receive and transmit.

Maximum IF Drive: The maximum IF drive level is specified. This may be applied to the Common port or the separate TXIF port. You may have specified a specific IF drive level and it will fall into



one of the 5 ranges listed. The transverter will produce full power at your desired drive level but adjustment of the TXIF control will be necessary. This will be covered in the **“Set-Up”** section **Antenna Option:** The RF output option is either a single port (Common RF) for both TX and RX or there will be two separate ports, one RX and one TX. For the common port, a PC board RF relay is utilized that allows the output configuration to be changed at anytime if the user changes their system requirements at a later date. This will be covered in detail later in this document. The common port relay (the TR relay) is controlled by the Push-to-talk (PTT) circuit

Transmit Enable: The TX Enable for the transverter is the RCA cable and connector supplied from the 9 pin AUX connector. The TX Enable is on Pin 5 regardless of your choice of PTT to ground or a Positive Voltage for TX enable. This connection is made directly to your transceiver. The TX Enable function energizes the internal sequencer unless specified. It will be indicated in the Sequencer section.

Other Options: If other options or special function are ordered that require access to the transverter, they will be indicated as such on the designated pins. Options include but are not limited to DC power enable, LNA bypassing, remote power sensing.

Other Notes: If any specific instructions or configurations are required, it will be noted here. In example, “LNA switching installed with Bias on the coax”

Sequencer Outputs: All Sequencer outputs are contained in the 6 conductor cable extending from the AUX connector and are indicated by color on the chart.

Theory of Operation: The basic principle of a transverter is to convert a chosen band of operation to the transceiver of choice. Following the recommendations of the transceiver’s operation manual for transverter use (or not) is the most important aspect of correct transverter operation. If configured correctly, the transverter will convert both transmit and receive signals to a new band of operation and seem “invisible” to your transceivers operation. In simple terms, the transverter will not improve the performance of your transceiver but if configured correctly, will not cause any degradation of performance in any way and will appear as if it was meant to be on that “New” band all the time.

Interfacing and Operation: Interfacing the transverter to the transceiver is easy. After reviewing the front page configuration and verifying that the transverter is configured correctly, proceed with the connection. If you find that something is not correct in the configuration, either make the correction by following the directions in the “Configuration Options” section later in this manual or consult DEMI with your issue.

If you have configured a DEMI transverter before, use the following steps as a guideline to complete you transverter install. If not, the following steps may be lengthy but are basically simple. Each step has a brief explanation of how and why the procedure is to be completed. Let’s review what is required to make this interface complete.

The interfacing starts with a complete understanding of your transceiver and manual. The manual should cover the setup for transverter operation if it has transverter ports and the

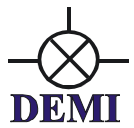

connections to be made. Some transceivers do not have ports but may still be interfaced with some instruction. Some transceivers are simple and some are complex. Some transceivers may have more than one correct way of interfacing. Hopefully, you have decided on how this transverter is to be interfaced at the time of order so we were able to configure the transverter to fit your requirements. But remember, all configurations are user changeable and detailed instructions are included later in this document

Start the interfacing with good quality 50 ohm cables for the IF (28 through 144 MHz) and the 10 MHz connections. These connections are low level (10 watts or less) and are BNC connectors on the transverter. Your transceiver may have various other types of connections. We find that simple RG-58 type BNC cables work fine with or without adapters to your transceiver.

All transverters require a way of enabling the Transmit function with a PTT (Push to Talk) control (to ground or positive voltage on TX) that follows the transmit mode of the transceiver. The PTT input to the transverter is a RCA connector from the AUX connector cable. Most transceivers have RCA connectors for PTT outputs but some have various different connections. Be sure to have whatever cable/connector/adaptor that is required ready to go. The AUX connector of the transverter will contain all sequencer connections and any other special requirements you requested. The AUX cable is supplied and matches the connector and it's sequencer functions should be tested before interfacing directly to your system.

The DC power cable is supplied with the transverter and needs to be prepped on the power supply end. It is important to fuse this line if using a battery or a high current power supply or adjust the current limit on you power supply for set up. Review the pictorial below of the rear panel and the rear panel of the transverter.

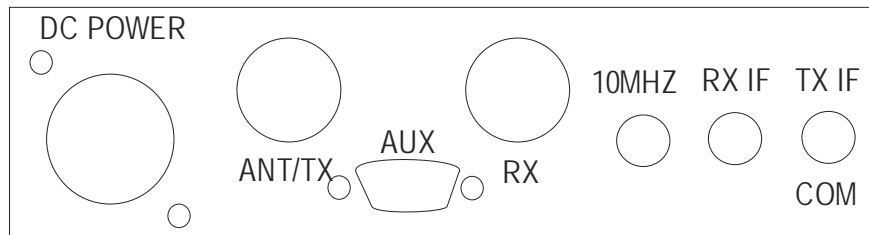

Rear Panel view

Connect your transceiver to the transverter: Interfacing the transverter to the transceiver is easy. After reviewing the front-page configuration and verifying that it is configured correctly for your purpose, begin cabling. **An Important note:** It is recommended that during the initial setup of the transverter, that it is not connected to your complete system with a HPA or mast mount LNA. All aspects of the transverters performance should be tested before a complete installation is made to an existing system. Drive levels need to be established and proper switching needs to be verified before complete integration for protection of your existing system.

After connecting the DC power cable to the power supply of choice, connect the DC POWER to the transverter. It is a twist lock. 13.8 volts is optimum but the transverter will operate normally from 11 to 15 volts. Remember the fuse! Now cycle the power switch on the transverter and verify that the "ON" light shows Red. Leave the transverter powered on.



1. The transverter has a synthesized local oscillator with its own reference source but if you are after extreme accuracy and best phase noise, you can connect an external 10 MHz source of any type (GPS, TCXO, or Rubidium) at a level of +6 dBm +/- 6dB. When connecting an external source to the 10 MHz connector, if the level is correct, it will automatically switch in and the Power "ON" light will turn "Green" to indicate the use of the external source. Remove the external 10 MHz source connection and the LED will revert back to red. When done playing with the RED/GREEN lights, power the transverter down.

2. Connect the "Push-to-Talk" line from the transverter to your transceiver. It is the RCA cable/connector out of the AUX connector. Refer to the configuration sheet for how it is set up and then connect it to your transceiver. Most transceivers have a connection to ground during transmit. (PTT-L or to Ground) or may be called something else. (TX ENABLE) Be sure to verify the connection and/or type of connection. Some source a positive voltage on Transmit. Review your transceivers manual for keying external devices such as a Power Amplifier. Consider the transverters keying the same as a power amplifier. The transverter requires either a connection to ground that sources less than 5 ma or will sink a positive voltage of 2-17VDC at 2 ma. When complete with this connection, be sure your transceiver is powered OFF!

3. Connect the IF cable/cables. The transverter may have a single common IF port or two separate ports, TXIF and RXIF. The common port has both TX and RX signals and should connect to a similar port on your transceiver. Refer to your transceiver's manual to determine how the IF connections are to be made if your transceiver is "Transverter Ready". If the transceiver does not have transverter ports, you will connect directly to the antenna port of your transceiver. Make whatever connections you need to do to establish the connection (adapter/adapter cable). **CAUTION:** Do not power the transceiver on after making this connection!

4. Antenna Connections. If you have requested a common RF connection, the "ANT/TX" port has both RF frequency TX and RX functions. If separate TX and RX ports were ordered, the internal transfer relay of the transverter was bypassed. The separate ports are labeled ANT/TX and RX. No matter what, connect your antenna system or dummy load with a power meter to the ANT/TX connector on the transverter. If you have a separate RFRX connection, it would be best to place a 50 Ohm dummy load on it for initial testing.

5. If you have a transceiver without a transverter port and the IF cable is connected to the antenna port, disconnect the IF cable from the Transverter. Now power up your transceiver and set it to the IF band of choice that matches the transverter (10, 6, or 2 Meters). Then, adjust the output power of the transceiver to minimum. Even if you have the "Maximum 10 Watt IF Option" installed, the transverter will operate normally at much less power. This is recommended to eliminate the possibility of radiated energy within the transverter from the transceivers output power to couple in to other circuits and produce spurious emissions. The basic transverter only requires a couple of milli-watts to operate. The 10 watt IF option is a 50 ohm dummy load with a coupling point that samples a small amount of drive energy in to the TX circuit. The rest is absorbed in the dummy load but will radiate within the enclosure.

After the transceiver power is adjusted, power off the transceiver and reconnect the IF cable to the antenna port.

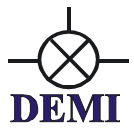
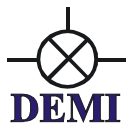

6. Power the Transverter on. If you have an external 10 MHz source, the "On" light should be green. Now, power on your transceiver and understand that all transceivers are not alike. You may hear a relay click and the TX light of the transverter may cycle but if the TX light remains on, power off your transceiver! If the TX light remained on, there is an incorrect connection to the transceiver regarding the PTT line or your transceiver was locked into transmit. Re-verify the configuration of the transverter and your transceiver's manual for keying external devices. If the set up is working correctly, keying the transverter is as simple as squeezing the MIC button, or pressing the TX button on the rig. If you test it in the CW mode, **do not use Full Break-In !!!!** The transverter is sequenced and has a built in delay and worst of all, has mechanical relays that will fail if RF is applied at the wrong time. You can use Semi Break-In but increase the delay so not to hear any relay chatter.

7. Now, if you have a in line power meter or have been looking at the relative power meter, you have noticed very little output power. This is because the TXIF gain needs adjustment. Our recommendation is , if using a low level transverter port, and if your transceiver has any method of adjusting the output power of this port set to maximum output power.

If you are using the Antenna port for your IF line, adjust your transceivers output power to minimum output power it will operate at. The transverter has plenty of adjustment to compensate its drive level.

Then turn the transverter over and remove the bottom cover. Then with a small slotted tuning tool or small screw driver, the TXIF gain control may be adjusted. The transverters TXIF control is adjusted to maximum attenuation when it left the factory. Fit the adjusting tool into the slot of the TXIF gain control, place the transceiver in the CW mode and go key down. Adjust the control to obtain the maximum specified output power or until 9 bars are lit on the relative power meter on the transverter. When complete, verify the SSB mode and FM if you use it at all. If you transceiver is balanced, all modes should have equal power. On SSB, it should peak at 9 bars. If you cannot obtain full output power, verify your transverter port output power. If you are using a High Power IF drive through the antenna connector, do not assume the output power level is set to low. Verify all possibilities before increasing the output power of the transceiver. If all fails, consult DEMI with your issues before increasing the drive power beyond 10 watts.

8. Receiver gain adjustment. Be sure you have a good antenna or a good dummy load at the desired frequency of use connected to either the antenna port or the RFRX port. Observe the noise level in the transceiver on the "S" meter and by ear. If it is too high, adjust the RXIF gain control in the transverter until a slight noise increase is heard in the transceiver or just a slight movement in the "S" meter is detected. Power the transverter on and off to verify the change. You should be able to "hear" the difference of on and off. The RXIF gain may be increased beyond this point, but it will start to degrade the dynamic range of your transceiver. It is all user preference. If you plan to use an external or mast mount LNA, this level will need to be re-adjusted. Find a signal on the band or use a signal generator to determine the minimum signal level.

9. You may re-adjust both RXIF and TXIF again at any time if desired but normally once set, you forget about it unless you change transceivers or add power amplifiers or receive preamplifiers. Install the bottom cover. The sequencer AUX connections may be now wired for your installation. If you require something other than what is indicated on the front page, please

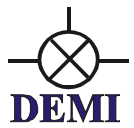

see the **Option Setup** section for further details. Also read further about interface and testing a mast mounted LNA in that section.

10. Basically, the transverter is ready to use in its stand alone form but and may be now integrated into your more elaborate system. Connect as you wish to use it in your system. If your system requires the use of the sequencer or you desire to implement it please refer to the **Option Setup** section of this manual.

General Operation: General operation of the transverter, if everything is adjusted correctly, should be transparent to the transceiver and the user. Except for the frequency read out, (if your transceiver doesn't allow its display to be adjusted for transverter operation) it will be like operating on with your transceiver on any other band. All of the functions of the transceiver (filtering, DSP, split band operation, dual VFO) will be transposed to the frequency band of the transverter.

Some cautions should be taken when operating CW or VOX. Operating the transverter in a "Full Break-in" mode is not recommended. Because of the mechanical relays and the sequencer in the transverter, there will be too much delay to operate "Full Break-in" effectively. AND—the relays would be abused if "Full break-in" is enabled. It is best to operate in "semi break-in" and adjust the delay of the PTT on your transceiver to match your comfortable CW operating speed in a way that the delay will hold the PTT until your transmission is complete. Since all transverters will be delivered with the sequencer enabled, this delay will need to be longer to allow all components within the system (Power amplifier, LNA, relays, if installed in the system) to complete their transition if utilized. If the stock transceiver is to be used alone, the transceiver PTT signal may be connected directly to the transverters PTT input if the sequencer is bypassed. This will shorten up the delay but will not allow "full break-in" without relay chatter. See the **Sequencer Operation** in the **Option Setup** section of this document.

Option Setup:

Common or Split IF Option: The IF configuration may be change at any time according to the type of transceiver you are utilizing. Refer to the Component placement or schematic for clarification. The component designators are also screened on the circuit board.

K2 is the common IF relay. To split the IF lines into separate RXIF and TXIF, you only need to connect the RXIF connector with a short piece of coax to the point on the board between C4 and C5. Attach the shield of the coax to the cleared metal at that point on ground. Then remove C4. Leave the common connection at the TXIF input. With this set up, the RF sense protection circuit and any TX gain or attenuation is still in place. Reverse the procedure if you want to change to or back to Common IF by installing C4 or use a short piece of wire to bridge the gap.

TXIF Drive Level Range change: The TXIF drive level range can be changed at anytime to conform to your transceiver type. Basically, there are 5 configurations for maximum usable drive levels. For high IF drive levels between 1 and 10 watts, the 50 Ohm load (Load 1) will be installed with a low value capacitor of either 1 pF for 2M IF frequency and a 5 pF for 10 M operation in the C13 position. A level up to 1 watt requires a 10 pF for C13 for all IF frequencies. For a level up to 100 mW requires the removal of LOAD 1 and then replace C13 with a 100 ohm chip resistor. Up to 10 mW is the standard level for the transverter and C13 should be a short or a 1000 pF chip capacitor. Anything below 1 mw will require a gain stage installed in IC2 position At the -10dBm level, install a MAR3 or any MMIC that will produce around 13dB gain operating at +5VDC at the IF frequency. If more gain is required, A MAR 6 will work with inputs as low as minus 20dBm. To



install IC2, if a chip resistor in its position, it will need to be removed. R13 (the TXIF gain control) will then need to be re-adjusted for the correct drive level..

IMPORTANT NOTE: When re-testing, do not assume that since your output power of the transverter is low that it is because you do not have enough IF drive. Please consult DEMI if you have problems obtaining full output power with your new specified drive level.

Common or Split RF connections: The RF connections may be reconfigured at any time. If you desire a separate TX and RXRF connection, install a type "N" connector in the RX hole on the end panel and connect a coax from it to the point on the board between C9 and the LNA board. The shield is connected to the exposed metal on ground. Then remove C9. This connection does not have a DC path to ground to bleed static but it is assumed that if you desire a separate RFRX connection, you have external protection devices installed. The TXRF (ANT/TX) line remain as it is. If you have separate ports and wish to make them common, reverse the procedure adding C9 and re-installing L2 if it was removed.

Sequencer: The sequencer in the transverter is ready for operation as specified on the front cover sheet. Its configuration may be changed at anytime. The transverter is keyed on the 4th and last step. It is wired to the #4 point on the circuit board in the sequencer section. This is a "LOW" on transmit. The other connections are indicated on the front page and wired to the AUX connector with color code.

Step 1 +12VDC on RX for a preamp @ 750 mA maximum

Step 2 +12VDC on TX for a TR relay (around the preamp) @ 750 mA maximum

Step 3 Ground on TX to key a HP power amplifier. Sinks 100 mA maximum

Optional Sequencer Connections:

Step 1 and 2: They can be connected to switch higher DC voltages. The DC voltage is applied to the DC1 and DC2 connections on the board (30VDC maximum).

Step 2: TL2 is a secondary connection to the second step. It is a "LOW" on transmit. It can be used to drive a relay or key an amplifier but an external isolation device should be utilized.

Caution! It will sink 50 mA maximum

Step 3 and Step 4: They have secondary outputs that are both "High" on transmit. They are labeled PH3 and PH4. These should be isolated from devices that require high currents and are intended to drive low current devices or Pass transistors or FETs. They will source 50mA.

Sequencer Bypassing: The transverters sequencer may be by-passed to eliminate switching time delays but is only recommended if it is to be used without any other system components such as LNAs or power amplifiers. In this case the external PTT input of the transverter, Pin 5 of the AUX connector may be connected directly to the Amplifier's PTT input (see component placement document) between CR9 and C33 labeled PTT-L if using a signal to Ground to key the transverter or to the PTT-H near R22 if positive voltage keying is utilized. If you bypass the sequencer, remove the wire coming from the "4" position of the sequencer.

Mast Mount Preamp (LNA) Switching: Provisions have been made to provide DC bias and switching of a mast mount LNA either directly on the ANT or RFRX coax or through the AUX connector. Step 1 of the sequencer is utilized for any LNA. A fused line can also be implemented. The socket for the fuse is located under the DIGILO synthesizer board. Remove the two screws holding the board in place and install a fuse of up to 2 Amps. A 1 Amp fuse is provided with the

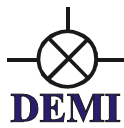

AUX cable assembly. The fuse is directly connected to the step 1 output. Re-install the two screws. From the output of the Fuse, the DC power can be routed to a switch mounted on the front panel of the transverter and then to the Pin 1 of the AUX connector or to the LNAB connection on the circuit board near C2 if the mast mount LNA requires bias on the coax. A choke is installed between the LNAB connection and the RFRX transmission line acting as a Bias "T". Then the bias to the LNA is then sequenced or switch out of line (with the front panel switch) if it is desired to bypass it. See the Components List for the optional Choke value. **CAUTION:** Remove L2 from the circuit or the fuse will blow instantly. The LNAB choke may be repositioned if a separate RFRX port is used.

Relative Power Meter: The bar graph display is a relative power meter and is driven by the directional coupler and RF detector circuit found in the Low pass filter section of the board (CR2, R1,R2,C1) RF is detected and converted to DC voltage and conducted to the Bar graph display on the front panel. If you find that you operate the transverter at any other level than what we have calibrated it to (either 25 or 50 watts = 9 bars) you may change it by adjusting VR1 on the display board. You may also send the detected voltage out through the AUX connector. Select a unused pin and make the connection.

Synthesizer Frequency Change: This is the newest option available. You may select at any time, any desired IF operating frequency from the list of available frequencies. Just short the two pads marked with the indicated number specified below with a simple solder connection. The DIGILO is marked "0-7 Frequency Select". The selections are listed below.

Frequency of Operation	Short pins
902 = 28, 903 =29	2
903 = 28	1,2
902 = 144, 903=145	0,1
903 = 144	0,2
902 = 50	2,3,4,5,7
902 = 52	0,1,3,4,5,7

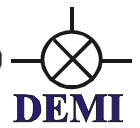

DEM L33HP Component List

Resistors (R) values are in Ohms and are (1206) chips unless otherwise specified.

R1 100	R15 220	R29 51	R43 10K	R57 10K
R2 51	R16 8.2K	R30 8.2K	R44 10K	R58 10K
R3 10K	R17 470	R31	R45 10K	R59 220
R4 220	R18 36	R32 36	R46 10K	R60 10K
R5 1K POT	R19 10K	R33 220	R47 10K	R61 10K
R6 10K	R20 10K	R34 10K	R48 10K	R62 10K
R7 220	R21 Not used	R35 51	R49 10K	R63 1K
R8 Not used	R22 10K	R36 10K POT	R50 470	R64 1K
R9 1K	R23 220K	R37 10K	R51 1K	R65 1K
R10 220	R24 10K	R38 1MEG	R52 22K	R66 10K
R11 220	R25 1MEG	R39 10K	R53 1MEG	R67 470
R12 220	R26 10K	R40 2.7K	R54 10K	R68 10K
R13 1K POT	R27 5.6K	R41 10K	R55 1MEG	R69 1K
R14 220	R28 470	R42 1MEG	R56 10K	R70 10K

Capacitors (C) values are in pF and are (0805) chips unless otherwise specified.

“T” = chip Tantalum, Band is positive. T

C1 100 (1206)	C17 0.1μF (1206)	C33 1000	C49 100
C2 100 (1206)	C18 100 (1206)	C34 27	C50 100
C3 1000 (1206)	C19 33 (0603)	C35 27	C51 33
C4 1000	C20 0.1μF (1206)	C36 0.1μF (1206)	C52 0.1μF (1206)
C5 1000	C21 4.7 or 10μF T	C37 0.1μF (1206)	C53 100
C6 1000	C22 1000	C38 100	C54 0.1μF (1206)
C7 3	C23 1000	C39 0.1μF	C55 100
C8 33 110mil	C24 1000	C40 1000	C56 0.1μF
C9 100	C25 0.1μF	C41 0.1μF	C57 22μF
C10 1000	C26 1000	C42 100	C58 4.7 or 10μF T
C11 1000	C27 1000	C43 33 (0603)	C59 4.7 or 10μF T
C12 0.1μF	C28 33	C44 0.1μF	C60 10μF
C13 configuration	C29 1000	C45 100	C61 100μF
C14 100	C30 100	C46 100	C62 100μF
C15 1000	C31 100	C47 100	C63 0.1μF (option)
C16 1000	C32 4.7 or 10μF T	C48 100	C64 4.7 or 10μF T (option)

All inductors are specified.

L1 1000nH (1008) (option)	L10 1000nH (1008)
L2 1000nH (1008)	L11 33 nH (0603 chip inductor)
L3 33 nH (0603 chip inductor)	L12 33 nH (0603 chip inductor)
L4 33 nH (0603 chip inductor)	L13 1000nH (1008)
L5 1000nH (1008)	L14 1000nH (1008)
L6 39nH (1008)	L15 1000nH (1008) (option)
L7 82nH (1008)	L16 1000nH (1008) (option)
L8 39nH (1008)	L17 0.33μH molded choke (option)
L9 1000nH (1008)	



Solid State, Relays and Filter Components

Q1 MJD31	CR1 MMBD914	IC3 LM393
Q2 PMBT3904	CR2 HSMS-2800	IC4 PGA103
Q3 PMBT3904	CR3 MMBD914	IC5 PGA103
Q4 PMBT3904	CR4 HSMS-2800	IC6 MAR3
Q5 PMBT3904	CR5 HSMS-2800	IC7 PHA-1
Q6 PMBT3904	CR6 MMBD914	IC8 LM324
Q7 MJD32	CR7 HSMP3814	IC9 LM3914
Q8 PMBT3904	CR8 MMBD914	IC10 PMA2-33LN
Q9 PMBT3904	CR9 MMBD914	IC11 PMA2-33LN
Q10 PMBT3904	CR10 MMBD914	METER1 BARGRAPH
Q11 MJD31	CR11 MMBD914	M1 SYM-18H
Q12 MJD32	CR12 MMBD914	VR1 L7805CD2
Q13 PMBT3904	F2 900MHz(GY6N)	VR2 78M09 (optional)
Q14 PMBT3904	F5 900MHz(GY6N)	K1 RG-1
Q15 PMBT3904	F6 900MHz(GY6N)	K2 G6Y
Q16 PMBT3904	IC1 MAR3 (option)	K3 G5V
Q17 PMBT3904	IC2 MAR6 (option)	FUSE 1Amp

IC12 RA20H8994M or RA45H8994M1

LOAD MP930

TH Thermistor

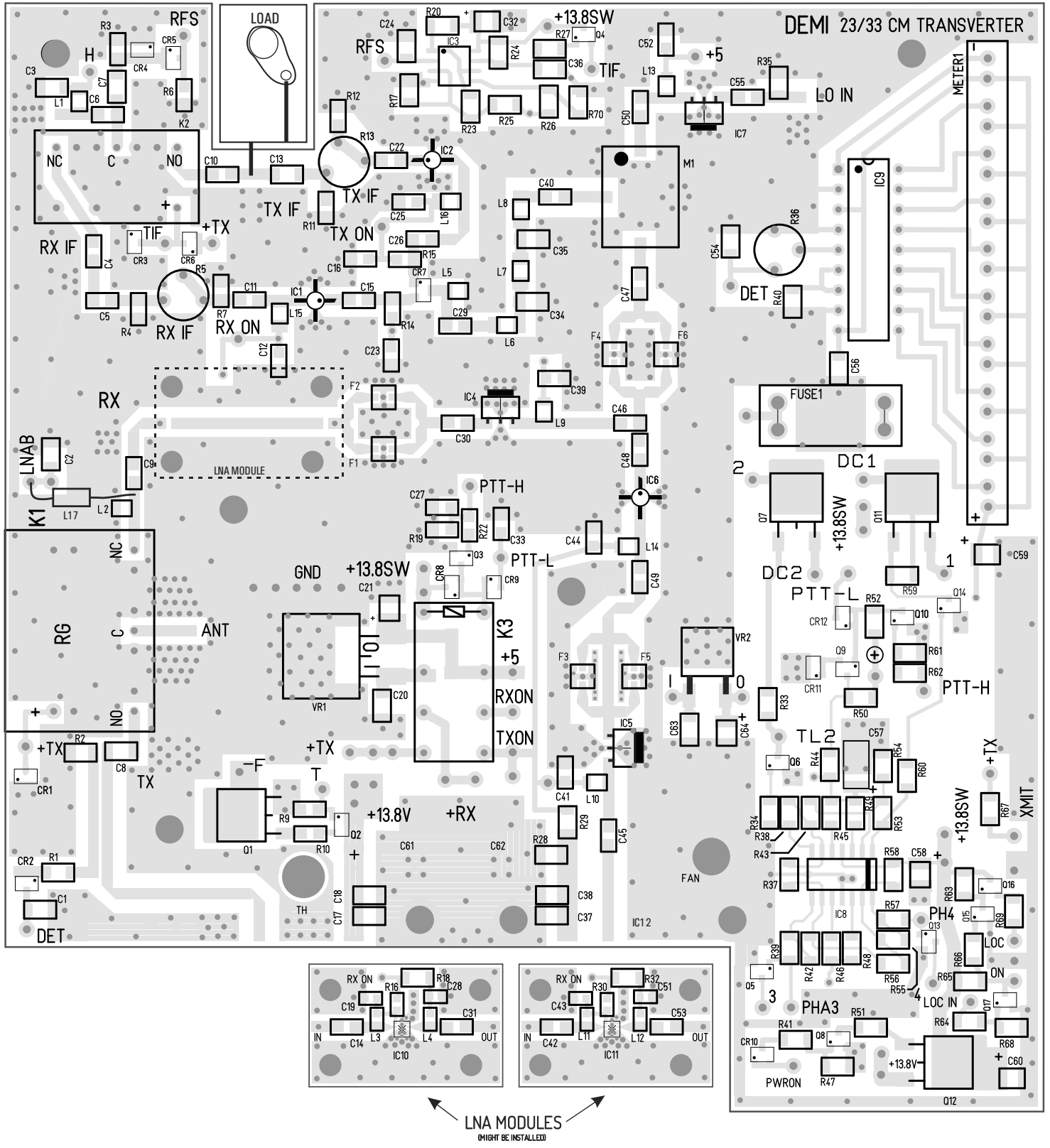
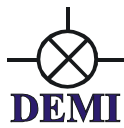

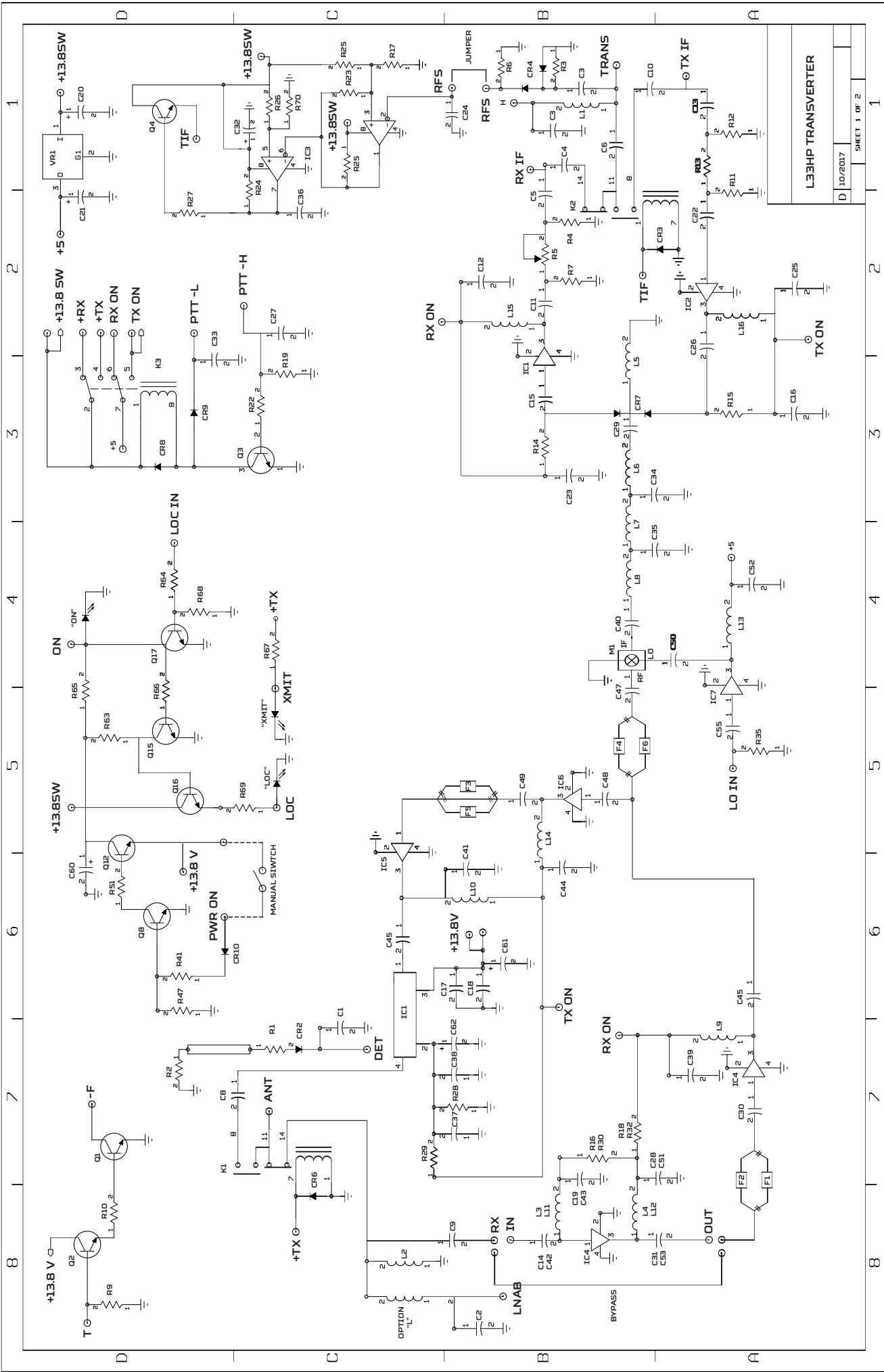

L33HP TRANSVERTER

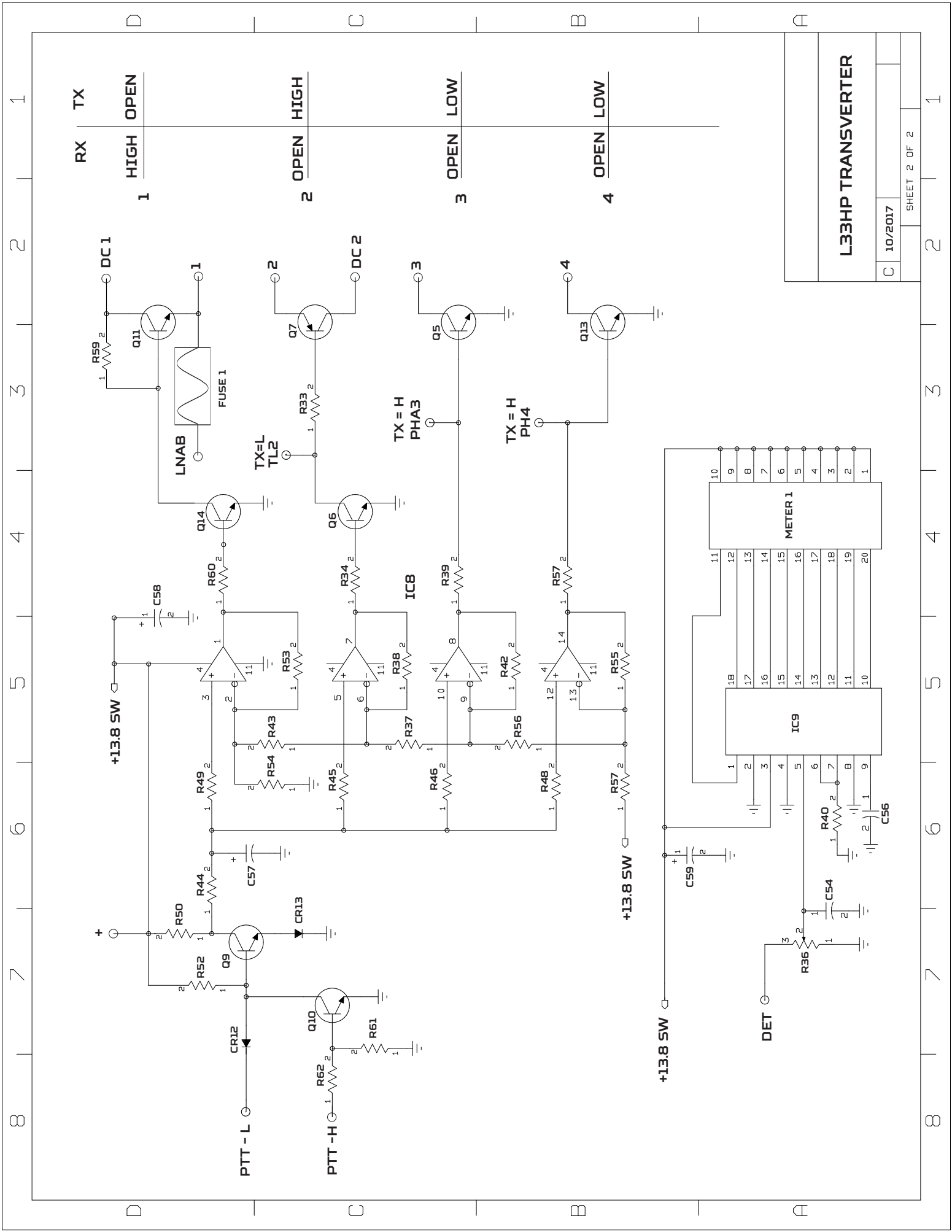

L33HP TRANSVERTER

C 10/2017

SHEET 2 OF 2

1

2

3

4

5

6

7

8

1

2

3

4

5

6

7

8