

REV A

**DEM TRS, TRSK and TRSCK
Transmit / Receive Sequencer**

Operation

The DEM TRS, based on a design by WB5LUA, is a time delay generator / sequencer that is intended to be used with any lash-up that requires separate DC switching circuits to control pre-amps, TR relays, transmitters, and power amps. The TRS is a stand alone unit that is triggered by either a ground-to-transmit signal (PTT GND) or is activated by applying a 1.5 - 16 VDC (TTL). At the time of activation, a R/C timing circuit in combination with a voltage divider network, begins to turn on each individual op-amp, (4 total) in sequence. The op-amps in turn drive their respected pass / switching transistor circuits. In its resting state, (receive) there is only one output transistor switched on. This may be used for a pre-amp or any other receive only device. When the TRS is activated, it first shuts off this output transistor and begins to turn on, in sequence, the other pass transistors. The final transistor also controls a set of isolated relay contacts. When the TRS is de-activated, it returns to its resting position in reverse order.

Specifications

Operation voltage: +8 to +16 VDC Circuit activation: PTT GND, Ground to transmit. Sinks < 1 ma TTL, Positive voltage keying, 1.5-16V. < 2 ma drain @ 13.8 VDC Outputs & ratings: 4 steps, 1 high, sources 200 ma. and 3 lows in un-activated state plus 2 isolated. Reverse in active state. 3 highs will source 3 amps. max. 2 sets of isolated contacts (common, norm. open, norm. closed) that are activated on the 4th step, and are rated at .6A @ 125 VAC, 2 A @ 30 VDC and 350 VDC Max. Full Sequence Time: \approx 500 ms. User adjustable by substituting resistor value in RC timing circuit.

Construction

NOTE: This assembly procedure assumes you will be using the designed enclosure. If the PC board is to be installed in your existing equipment, assemble all components and install. Attach hook-up wires after mounting. Remember that TIP 32's will only safely source about 500 ma with out a heat sink.

All components are through-hole. Refer to the provided schematic and component placement diagram for assembly. Install IC 1 first using standard ESD precautions. Then install all other components except Q6, Q8, and Q10. After assembly, examine for solder shorts and trim all excess leads off. Cut and strip ends of 16, 3" wires. Install wires in the following PCB holes: +13.8SW, TTL, PTT, TR, RX, LED, TX1, TX2, NO1, NC1, C1, NO2, NC2, C2, and GND. The assembled PCB may be tested for switching functions without the TIP 32 transistors (Q6, Q8, Q10) installed to avoid dis-assembly later if a assembly mistake has been made. Refer to "Voltage Test Point" chart below and test until you are confident. Install all of the RCA connectors in the back panel of the enclosure. Do not install the switch or LED in the front panel. Mount the PCB in the bottom of the enclosure with 4-40 screws and nuts. The screw heads should be on the outside of the box and use a 4-40 nut for a spacer. Now mount Q6, Q8, and Q10 with their insulation hardware. Place a shoulder insulator on a 4-40 screw and install it from the outside of the enclosure. (through the bottom) Install the TIP 32 and mica insulator over the 4-40 screw with it's shoulder insulator and with a nut hand tighten into place so that the leads of the TIP 32 leads line up with it's PCB mounting holes. Assemble the other TIP 32's and then trim the leads on the transistors and solder them on the surface of the PC board. You may need to loosen the PCB for proper alignment. **NOTE:** Tighten all of the mounting hardware before soldering the TIP 32's to prevent shorts. Finish wiring the enclosure by connecting the PCB wires to their appropriate connectors. Install the switch and connect the 13.8 VDC wire from the PCB to the bottom leg and then connect a wire from the 13.8 VDC RCA connector to the center leg of the switch. Install the long lead of a LED into the PCB hole TXLED. Insert the LED into the enclosure marked XMIT. solder the short lead to the ground pad by the mounting hole. Install the other LED into the enclosure hole "On" and solder the short lead to the grounded lead of the XMIT LED. This will hold it into place. Solder the wire from the PCB hole LED to the long lead of the "On" LED. Now install the GND lug on the

enclosure with 4-40 hardware. This should be used as protection if you plan to switch other than 12 VDC through the relay contacts. Have Fun!

Testing: Verify the following voltages or refer to the chart in case of difficulty. Please allow for different voltages if other than 13.8 VDC is used for a supply. Component tolerance may alter voltages by 5 % or more. The timing may be altered by adjusting the value of R5. A extra 10K resistor is in the kit to shunt across or to place in series with R5 after assembly to alter the switching time. Feel free to experiment.

Voltage test points

Test Point	Un-activated	Activated
IC1, PIN 3,5,10,12	.8 V	13.5 V
IC1, PIN 1,7,8,14	.1 V	12.2 V
IC1, PIN 4, VCC	13.8 V	13.8 V
IC1, PIN 11, GND	0 V	0 V
IC1, PIN 2	2.6 V	2.8 V
IC1, PIN 6	5.3 V	5.6 V
IC1, PIN 9	8.0 V	8.3 V
IC1, PIN13	10.8 V	11.1 V
R11,Q3,Q4	13.5 V	.2V
R16, Q6	13.3 V	12.9 V
R21, Q8	13.3 V	12.9 V
R26, Q10	13.3 V	12.9 V

Parts List

COMPONENTS		HARDWARE	
C1	22 uf	1	Enclosure
C2	100 uf	7	4-40 x 5/16 screw
D1, D2	1 N914	10	4-40 nuts
D3	1N4000 type	13	RCA connectors
IC 1	LM 324	13	1000 pf disc Caps
K1	G5V DPDT	1	SPDT switch
Q1-Q5,Q7,Q9	PN2222	2	LED
Q6,Q8, Q10	TIP32A	3	Mica insulator
R27	1 K 1/4W	3	shoulder insulators
R3	22K 1/4W	4	Rubber feet
R4	470 1/2W	4	#4 Sheet metal screws
R9,14,19,24	1 MEG	1	#4 ground lug
R11	220 1W		
R16,21,26,28	470 1/4 W		
R1,2,5-8,10,12,13, 15,17,18,20,22,23,25	10K 1/4W		

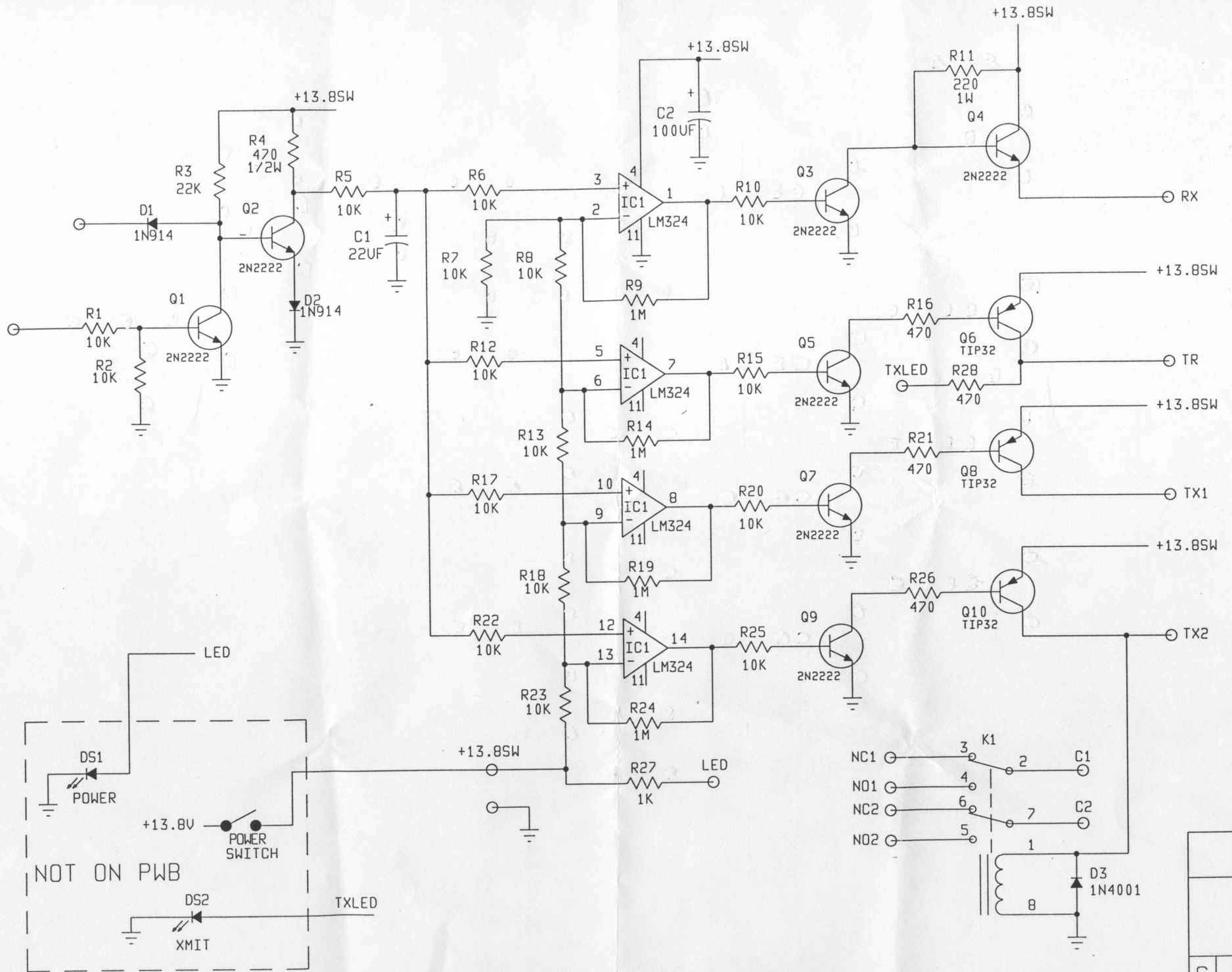

C
 B
 A

C

