

digiLO – A Wideband PLL Synthesizer

The digiLO is a Wideband Fractional-N / Integer-N PLL Synthesizer based on Maxim's MAX2870 capable of generating signals from 23.5MHz to 6GHz. It measures only 2" x 3" and comes programmed with over a hundred popular frequencies. A connection to an external 10MHz reference is provided. But the digiLO automatically switches to its on-board TCXO reference when its 10MHz external reference is not detected.

The recommended supply voltage for "+V" is 9V. But reliable operation is possible down to 7V. The digiLO is tolerant of supply voltages up to 15V. But operation beyond 9V results in excessive heating of the voltage regulator. So if 12V operation is desired, it is recommended to use a 27 Ohm 2-Watt resistor in series with the power connection. This should drop the voltage to the digiLO to a safer level. A +5V direct connection which bypasses the voltage regulator is also available.

The MAX2870's internal voltage controlled oscillator (VCO) operates from 3GHz to 6GHz. The MAX2870 generates output frequencies lower than 3GHz by inserting dividers after its VCO up to a maximum of 1/128. Every divider slightly increases the MAX2870's current consumption. Therefore, the supply current increases as output frequency decreases. Below 47MHz, supply current is a maximum of 200mA. And above 3GHz, the supply current drops to 130mA.

The 10MHz External Reference should be from a clean and stable source. Keep in mind that the digiLO's output is directly affected by the quality of its reference. The recommended input range for "REF IN" is 0dBm to +13dBm. At levels below 0dBm, the digiLO automatically switches over to its internal TCXO reference.

When the digiLO is locked to its external 10MHz reference, the "LOCK" output switches from 0V to 5V through a 200 Ohm resistor. This output can also serve as a simple indication of which reference (external or internal) is sourcing the digiLO. Up to 20mA can be safely sourced from this connection. Therefore, a LED can be connected directly from the "LOCK" output to ground.

The RF output of the digiLO appears on the "RF OUT" connection. The output level is virtually flat from 23.5MHz up to 2GHz. And it maintains a level of +2dBm \pm 2dB up to 3GHz. Beyond 3GHz, the output gradually falls to -10dBm at 6GHz.

Refer to digiLO's supplied Frequency Table to select the desired frequency with jumpers or solder bridges. Or install a DIP switch or an external switch. The digiLO's microcontroller constantly monitors for changes in the frequency select jumpers. Therefore, frequencies can be changed at anytime without having to power down the digiLO.

digiLO Frequency Table for Firmware v22.2.1										
INDEX	FREQ	FREQ SELECT JUMPERS								SUGGESTED APPLICATION
		7	6	5	4	3	2	1	0	
0	116.000									144-28
1	194.000								X	222-28
2	404.000							X		432-28
3	758.000							X	X	902-144
4	874.000						X			902-28
5	759.000						X		X	903-144
6	875.000						X	X		903-28
7	1152.000						X	X	X	1296-144
8	1268.000					X				1296-28
9	2160.000					X			X	2304-144
10	2276.000					X		X		2304-28
11	3312.000					X		X	X	3456-144
12	3428.000					X	X			3456-28
13	5616.000					X	X		X	5760-144
14	5732.000					X	X	X		5760-28
16	130.000				X					144-14
17	208.000				X				X	222-14
18	418.000				X			X		432-14
19	757.000				X			X	X	902-145
20	1151.000				X	X				1296-145
21	2159.000				X	X			X	2304-145
22	3255.000				X	X	X			3400-145
23	5615.000				X	X	X	X		5760-145
24	3407.667				X	X				(10368-145) / 3
32	50.100		X							50.100 MHz WSS
33	70.100		X						X	70.100 MHz WSS
34	144.100		X					X		144.100 MHz WSS
35	222.100		X					X	X	222.100 MHz WSS
36	432.100		X			X				432.100 MHz WSS
37	435.100		X			X			X	435.100 MHz WSS
38	902.100		X			X	X			902.100 MHz WSS
39	903.100		X			X	X	X		903.100 MHz WSS
40	915.100		X	X						915.100 MHz WSS
41	1275.100		X	X					X	1275.100 MHz WSS
42	1296.100		X	X			X			1296.100 MHz WSS
43	2304.100		X	X			X	X		2304.100 MHz WSS
44	3456.100		X	X	X					3456.100 MHz WSS
45	5760.100		X	X	X				X	5760.100 MHz WSS
46	3456.033		X	X	X	X				10368.100 MHz / 3 WSS
47	3456.014		X	X	X	X	X			24192.100 MHz / 7 WSS
48	28.100		X	X						28.100 MHz WSS
49	1420.000		X	X					X	1420.000 MHz WSS
50	2401.000		X	X				X		2401.000 MHz WSS
51	3400.100		X	X				X	X	3400.100 MHz WSS
52	3139.207		X	X			X			47088.100 MHz / 15 WSS

INDEX	FREQ	FREQ SELECT JUM PERS								SUGGESTED APPLICATION
		7	6	5	4	3	2	1	0	
112	823.000	X	X	X						1263-430
113	829.000	X	X	X					X	1269-440
114	833.000	X	X	X				X		1263-430
115	839.000	X	X	X				X	X	1269-440
116	1117.000	X	X	X			X			1263-144
117	1118.000	X	X	X			X		X	1263-145
118	1119.000	X	X	X			X	X		1263-146
119	1124.000	X	X	X			X	X	X	1269-145
120	1125.000	X	X	X	X					1269-146
121	1211.000	X	X	X	X				X	1263-52
122	1217.000	X	X	X	X			X		1269-52
123	1235.000	X	X	X	X			X	X	1263-28
124	1236.000	X	X	X	X	X				1263-29
125	1241.000	X	X	X	X	X			X	1269-28
128	42.000	X								70-28 & (50-29) x 2
129	44.000	X							X	(50-28) x 2
130	77.000	X						X		222-145
131	78.000	X						X	X	222-144
132	79.000	X					X			223-144
133	84.000	X					X		X	(50-29) x 4
134	88.000	X					X	X		(50-28) x 4
135	94.000	X					X	X	X	144-50
136	95.250	X				X				(220-29.5) / 2
137	95.500	X				X			X	(220-29) / 2
138	96.000	X				X		X		(220-28) / 2
139	96.250	X				X		X	X	(222-29.5) / 2
140	96.500	X				X	X			(222-29) / 2
141	96.750	X				X	X		X	(222-28.5) / 2
142	97.000	X				X	X	X		(222-28) / 2
143	97.500	X				X	X	X	X	(222-27) / 2
144	98.000	X		X						(222-26) / 2
145	100.625	X		X					X	(432-29.5) / 4
146	100.750	X		X				X		(432-29) / 4
147	100.875	X		X				X	X	(432-28.5) / 4
148	101.000	X		X		X				(432-28) / 4
149	101.250	X		X		X			X	(432-27) / 4
150	101.500	X		X		X	X			(432-26) / 4
151	101.750	X		X		X	X	X		(435-28) / 4
152	102.000	X		X	X					(435-27) / 4
153	102.250	X		X	X				X	(435-26) / 4
154	114.000	X		X	X			X		144-30
155	114.500	X		X	X			X	X	144-29.5
156	115.000	X		X	X	X				144-29
157	115.500	X		X	X	X			X	144.28.5
158	117.000	X		X	X	X	X			144-27

INDEX	FREQ	FREQ SELECT JUMPERS								SUGGESTED APPLICATION
		7	6	5	4	3	2	1	0	
159	118.000	X			X	X	X	X	X	144-26
160	119.000	X	X							144-25
161	120.000	X	X						X	144-24
162	170.000	X	X					X		220-50
163	171.000	X	X					X	X	222-51
164	172.000	X	X				X			222-50
165	190.000	X	X				X		X	220-30
166	191.000	X	X				X	X		220-29
167	192.000	X	X				X	X	X	220-28
168	192.500	X	X		X					222-29.5
169	193.000	X	X		X				X	222-29
170	193.500	X	X		X			X		222-28.5
171	195.000	X	X		X			X	X	222-27
172	196.000	X	X		X	X				222-26
173	381.000	X	X		X	X			X	432-51
174	382.000	X	X		X	X	X			432-50
175	383.000	X	X		X	X	X	X		435-52
176	384.000	X	X	X						435-51
177	385.000	X	X	X					X	435-50
178	402.000	X	X	X				X		432-30
179	402.500	X	X	X				X	X	432-29.5
180	403.000	X	X	X			X			432-29
181	403.500	X	X	X			X		X	432-28.5
182	405.000	X	X	X			X	X		432-27
183	406.000	X	X	X			X	X	X	435-29
184	407.000	X	X	X	X					435-28
185	408.000	X	X	X	X				X	435-27
186	409.000	X	X	X	X			X		435-26
187	850.000	X	X	X	X			X	X	902-52
188	852.000	X	X	X	X	X				902-50
189	853.000	X	X	X	X	X			X	903-50
192	984.000	X	X							(24048-432) / 24
193	990.000	X	X						X	(24192-432) / 24
194	996.000	X	X					X		(24048-144) / 24
195	1002.000	X	X					X	X	(24192-144) / 24
196	1008.000	X	X				X			(10368-1296) / 9
197	1022.400	X	X				X		X	(10368-144) / 10
198	1065.000	X	X				X	X		(5760-435) / 5
199	1065.600	X	X				X	X	X	(5760-432) / 5
200	1078.000	X	X			X				(2300-144) / 2
201	1079.000	X	X			X			X	(2304-146) / 2
202	1080.000	X	X			X		X		(2304-144) / 2
203	1088.000	X	X			X		X	X	(2320-144) / 2
204	1104.000	X	X			X	X			(3456-144) / 3 & (10368-432) / 9
205	1116.000	X	X			X	X		X	(5760-1296) / 4
206	1122.600	X	X			X	X	X		(5760-147) / 5
207	1123.000	X	X			X	X	X	X	(5760-145) / 5

INDEX	FREQ	FREQ SELECT JUMPERS								SUGGESTED APPLICATION
		7	6	5	4	3	2	1	0	
208	1123.200	X	X		X					(5760-144) / 5
209	1127.000	X	X		X				X	(2304-50) / 2
210	1128.000	X	X		X			X		(2400-144) / 2
211	1135.000	X	X		X			X	X	(3456-51) / 3
212	1136.000	X	X		X		X			(10368-144) / 9
213	1140.000	X	X		X		X		X	(2424-144) / 2
214	1142.000	X	X		X		X	X		(5760-50) / 5
215	1242.000	X	X		X		X	X	X	(10368-432) / 8
216	1244.000	X	X		X	X				1296-52
217	1246.000	X	X		X	X			X	1296-50
218	1267.000	X	X		X	X		X		1296-29
219	1278.000	X	X		X	X		X	X	(10368-144) / 8
220	1656.000	X	X		X	X	X			(10368-432) / 6
221	1704.000	X	X		X	X	X		X	(10368-144) / 6
222	1987.200	X	X		X	X	X	X		(10368-432) / 5
223	2044.800	X	X		X	X	X	X	X	(10368-144) / 5
224	2176.000	X	X	X						2320-144
225	2254.000	X	X	X					X	2304-50
226	2256.000	X	X	X				X		2400-144
227	2280.000	X	X	X				X	X	2424-144
228	2484.000	X	X	X			X			(10368-432) / 4
229	2556.000	X	X	X			X	X		(10368-144) / 4
230	2624.000	X	X	X			X	X		(24048-432) / 9
231	2640.000	X	X	X			X	X	X	(24192-432) / 9
232	2656.000	X	X	X		X				(24048-144) / 9
233	2672.000	X	X	X		X			X	(24192-144) / 9
234	2952.000	X	X	X		X		X		(24048-432) / 8
235	2970.000	X	X	X		X		X	X	(24192-432) / 8
236	2988.000	X	X	X		X	X			(24048-144) / 8
237	3024.000	X	X	X		X	X		X	3456-432
238	3256.000	X	X	X		X	X	X		3400-144
239	3408.000	X	X	X		X	X	X	X	(10368-144) / 3
240	3936.000	X	X	X	X					(24048-432) / 6
241	3960.000	X	X	X	X				X	(24192-432) / 6
242	3984.000	X	X	X	X			X		(24048-144) / 6
243	4008.000	X	X	X	X			X	X	(24192-144) / 6
244	4464.000	X	X	X	X		X			5760-1296
245	4752.000	X	X	X	X		X		X	(24192-432) / 5
246	4780.800	X	X	X	X		X	X		(24048-144) / 5
247	4809.600	X	X	X	X		X	X	X	(24192-144) / 5
248	4968.000	X	X	X	X	X				(10368-432) / 2
249	5112.000	X	X	X	X	X			X	(10368-144) / 2
250	5328.000	X	X	X	X	X		X		5760-432
251	5904.000	X	X	X	X	X		X	X	(24048-432) / 4
252	5940.000	X	X	X	X	X	X			(24192-432) / 4
253	5976.000	X	X	X	X	X	X		X	(24048-144) / 4
254	100.000	X	X	X	X	X	X	X		100 MHz MARKER
255	1000.000	X	X	X	X	X	X	X	X	1000 MHz MARKER

digiLO Measured Phase Noise at Various Frequencies and Offsets				
Frequency	dBc/Hz @ 100Hz	dBc/Hz @ 1KHz	dBc/Hz @ 10KHz	dBc/Hz @ 100KHz
116MHz	-97	-112	-115	-120
194MHz	-92	-105	-115	-120
404MHz	-90	-106	-113	-118
758MHz	-90	-104	-109	-115
759MHz	-90	-106	-108	-111
874MHz	-90	-105	-106	-105
875MHz	-90	-105	-107	-113
1152MHz	-88	-100	-104	-115
1268MHz	-88	-100	-100	-105
2160MHz	-84	-98	-101	-108
2276MHz	-80	-95	-98	-108
3312MHz	-78	-92	-98	-102
3428MHz	-78	-92	-97	-100
5616MHz	-76	-88	-88	-100
5732MHz	-75	-90	-90	-100

digiLO 1v50 Bill of Materials		
DESIGNATOR	QTY	DESCRIPTION
C1,C8,C19,C20,C32,C34,C36,C37	8	1nF 10% 50V X7R 0402
C2,C6,C10,C12,C14,C16,C18	7	10nF 10% 16V X7R 0402
C3,C7,C9,C11,C13,C15,C17	7	100pF 5% 50V NP0 0402
C4,C5,C21,C22,C23,C24,C25,C26,C27	9	1uF 10% 10v X5R 0402
C28,C29	2	4.7uF 10% 16V SIZE B TANT
C30,C31,C33	3	0.1uF 10% 16V X7R 0402
C35	1	33pF 5% 50V NP0 0402
C38,C39,C40	0	DO NOT INSTALL
D1	1	BAS70-04 SOT-23
J1	0	DO NOT INSTALL
J2	0	DO NOT INSTALL
J3,J4	0	DO NOT INSTALL
Q1	1	MMBT4401 SOT-23
R1	1	5K10 1% 0402
R2	1	330R 1% 0402
R3,R24	2	1K00 1% 0402
R4,R5,R6,R7	4	49R9 1% 0402
R8,R13,R14,R15,R16,R17,R18,R19,R20	9	10K0 1% 0402
R9,R10	2	200R 1% 0402
R11,R12	2	100K 1% 0402
R21,R22,R23	0	DO NOT INSTALL
R25	1	330R 5% 0603
S1	0	DO NOT INSTALL
U1	1	MAX2870ETJ+
U2	1	PIC18F14K22-I/SS
U3,U4,U5	3	ADP150AUJZ-3.3-R7
U6	1	L78M05CDT (OR EQUIVALENT)
U7	1	SN74LVC1G3157DBVR
U8	1	74LVC2G14GV,125 (NXP)
U9	0	DO NOT INSTALL
Y1,Y2	0	DO NOT INSTALL

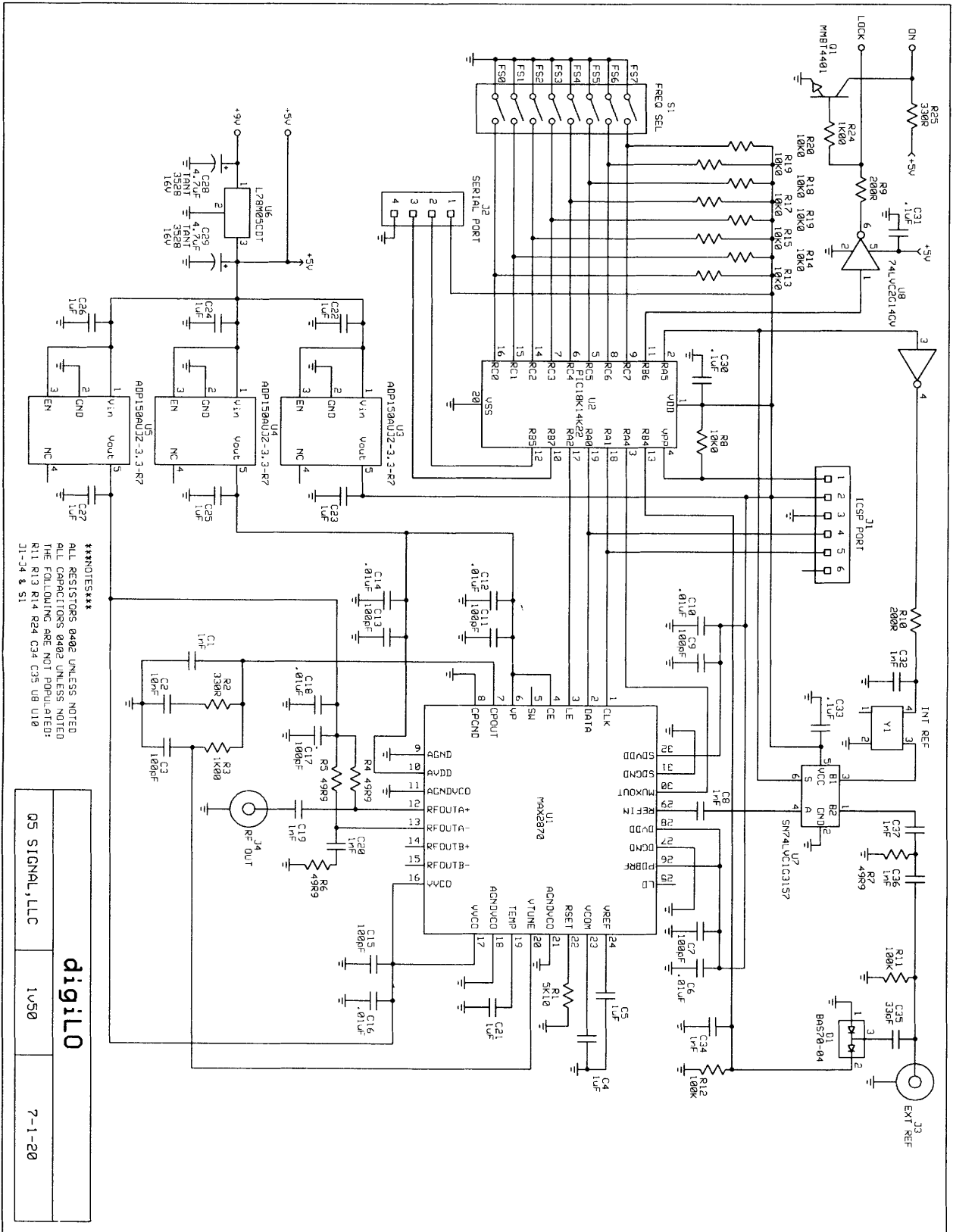

NOTES
 ALL RESISTORS PAGE UNLESS NOTED
 ALL CAPACITORS PAGE UNLESS NOTED
 THE FOLLOWING ARE NOT POPULATED:
 R11, R13, R14, R24, C34, C35, U8, U10,
 J1-J4 & S1

digiLO		
Q5 SIGNAL, LLC	1V50	7-1-20

Issue Date : January 11, 2018

Part Number: XTCLH10M000CHJA1P0 (Frequency: 10.000000MHz/ Size: 5.0 x 3.2mm)

Item	Specification
Supply Voltage: Vcc	-0.6~+6.0V
Control Voltage: Vc *1	-0.6~Vcc+0.6V
Storage Temperature Range	-40~+85°C

*1 And not to exceed the maximum value of Rating Supply Voltage.

Electrical Characteristics.

Item	Specification	
5-1	Nominal Frequency	10.000000MHz
5-2	Operating Temperature Range	-40~+85°C
5-3	Supply Voltage : Vcc	DC: +3.3V±5%
5-4	Current Consumption	3.0mA /max.
5-5	Output Level	Hi : 90%Vcc min. Lo : 10%Vcc max.
5-6	Load Condition	15pF±10%
5-7	Output Wave	CMOS
5-8	Frequency Characteristics	
5-8-1	Frequency Shift by Temperature	±0.28ppm max.(-40~+85°C) from initial value @+25°C)
5-8-2	Frequency Voltage Coefficient	±0.1ppm max. (DC:+3.3V±5%)
5-8-3	Frequency Load Coefficient	±0.1ppm max. (15pF±10%)
5-8-4	Frequency Aging	±0.5ppm max. (1year.) (@+25±2°C)
5-8-5	Frequency Tolerance after Reflow-soldering	±1.0ppm max. (2times.)
5-9	Frequency Tolerance	±0.5ppm max. (@+25±2°C, Vc:+1.5V)
5-10	Voltage Control Range	±3.0 ppm min. ±6.0 ppm max. (Vc:+1.5V±1.0V) Positive.