

## DEM 902/3-144HP and 902-28HP High Power 33 cm Transverter

### Specifications

Frequency range:	902/3 MHz. = 144 MHz. or 902 MHz. = 28 MHz
Noise Figure and Gain:	<1.5 dB NF, > 17 dB Gain with a +5 dBm IP3 input!!
Power Output:	>30 Watts or 60 Watts. Lower levels with different configurations
TXIF Drive level options:	-20dBm to 10 watts maximum (need to specify)
DC Power requirements:	13.8 VDC nominal. 11 to 16.5 VDC operational at reduced ratings.
DC Current drain:	10 and 20 Amps depending on output power level.

### General Information:

Down East Microwave's new High Power 33 cm Transverters are now available. The transverter, the [DEM902/3-144HP](#) may be ordered with many different IF and RF configurations as well as a 28MHz IF version. Substitute 28 for the 144 in the part number. The high power versions are not available as a kit. They are the combination of our standard 902/3 transverter and our new 3340PA and 3370PA assembled in a single enclosure. This combination allows for many simplified applications eliminating extra cabling and connectors.

The transverter may be configured with common or split IF circuitry setup for your desired level. The IF switch may be bypassed if your transceiver has separate ports. Lower drive levels may be used (-20dBm) if the attenuators are bypassed and a TX IF gain stage is installed. All IF connections are BNC connectors.

The standard RF configuration is separate TX and RX ports. A common RF switch option may be installed for an additional charge. The common RF switch may be bypassed for separate TX and RX ports if you so desire later. The RF ports are type N connectors only. Keying the transverter is done by either a voltage (PTT-H) or a ground on transmit (PTT-L). It is not RF sensed. The transverter has an auxiliary connection to power a external TR switch or a power amplifier.

### Circuit Description:

Looking at the 902/3 transverter circuit board, the first thing that is noticed is the absence of the printed hairpin filters.

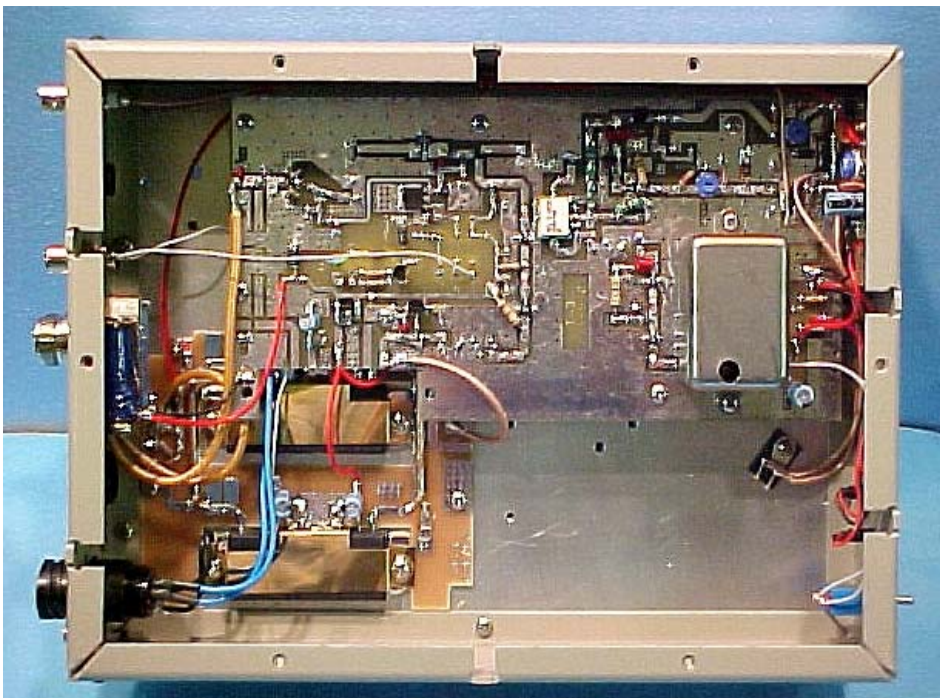

Although they were a very important feature of the traditional "No-Tune" transverter design, they have been replaced with miniature 3 pole helical filters. The use of these filters is the reason for the increased performance of the design and the "narrowing" of the operation bandwidth of the receive converter section and eliminating LO and out of band harmonics being passed through the transmit section. Producing a 28 MHz IF version is now simplified and achieves better performance of anything in the past.



Below is a list of standard features found in the 902/3 MHz line of transverters.

1. A high level mixer and local oscillator output of +17dBm after it is double filtered to reduce noise in the mixer.
2. A tuned low noise PHEMT FET low noise amplifier with LC input circuitry that is biased for high third order intercept performance. This improves out of band performance before filtering.
3. 2 separate 3 pole helical filters in the RX stage before the mixer that narrows the operation bandwidth of the transverter.
4. A high level IP3 performance second RX gain stage that will not compress before the mixer.
5. Built in IF switching and level control of up to 10 watts of drive.  
Additional transmit filtering to produce second harmonic levels of under -65 dBc and local oscillator leakage of -80 dBc.

These features combined with either a 30 or 60 Watt amplifier makes a perfect stand alone transverter for any use, portable or home station.

### **902/3-144HP and 902-28HP Theory of Operation**

The theory of operation is as follows. A local oscillator of 189.5/189.75 MHz is multiplied 4X for a 144/145 MHz. IF and a 174.800 MHz is multiplied 5X for the 28/29 MHz IF. Both are filtered, and amplified to the +17dBm level and is injected into a high level mixer. In receive, the 33 cm signal enters through either the RX port or the common antenna port. It is amplified by a high level, tuned input PHEMT FET low noise amplifier that has approximately 15-16 dB of gain with <1.0 dB noise figure. The amplified signal then passes through a 3 pole helical filter that allows approximately 20 MHz of amplified bandwidth. This signal is then amplified by a high level MMIC before being filtered by a 3 pole helical filter that further restricts the receivers operational bandwidth. This signal enters the high level mixer and exits the IF port of the mixer. It then passes through a VHF band pass filter and optional high IP3 gain stage with a variable attenuator. Then depending on the configuration, it will pass through the IF switch or not before becoming available to the 2 meter or 10 meter receiver.

On transmit it is a reverse process. The 2 or 10 meter transceiver applies a signal of up to 10 watts of drive and it is then switched, attenuated and filtered before entering into the mixer. The 33 cm transmit signal then exits the mixer and is filtered by a 3 pole helical before being switch to the transmit gain stages. It is then amplified up to approximately +15 dBm before it is filtered again to reduce the LO component even further. At this point, the signal is sent to the power amplifier of choice, 30 or 60 watts before either exiting the TX port or the common antenna port.

Other special options may be included in this version of transverter and may become standard in the future as this product line develops. If you have a special request, please consult us with your specifications. Below is a standard block diagram of the HP version transverters.

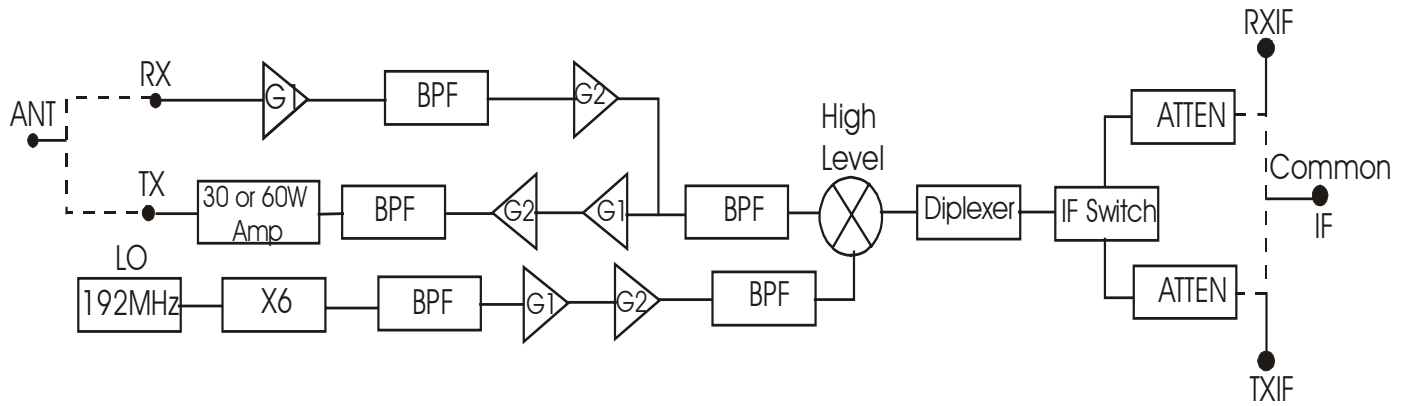

902/3-144 & 902-28 Front



902/3-144 & 902-28 Back

Above model configured w/ optional common IF and common RF options installed.